

**DALI MSensor OTD SFI 30 PIR 10DP DA WH**

DALI-2 multi-sensor



DALI MSensor OTD SFI 30 PIR 10DP DA WH



Typical application

**Product description**

- \_ Sensor developed to work with the latest DALI specification
- \_ Monitoring of ambient light and occupancy detection
- \_ Individual adjustment of the parameters with configuration software
- \_ Power supply via DALI line
- \_ Shutter for preventing occupancy detection in specific areas
- \_ Small dimensions allowing easy and inconspicuous integration in luminaries
- \_ Wide range of accessories allowing extended application range
- \_ 5 years guarantee (Conditions at <https://www.tridonic.com/manufacture-guarantee-conditions>)

**Housing properties**

- \_ Casing: polycarbonate, white
- \_ Type of protection up to IP66

**Note**

- \_ Tridonic DALI MSensor G3 family sensors are developed according to DALI Standard EN 62386-101 Ed.2, also known as DALI-2. To be able to use the sensor in such installation, an application controller is necessary.
- \_ List of approved application controller can be found on our WEB page in "Downloads" in document "Application\_controllers\_MSensor\_G3.pdf".

**Website**

<http://www.tridonic.com/28004440>



**DALI MSensor OTD SFI 30 PIR 10DP DA WH**

DALI-2 multi-sensor

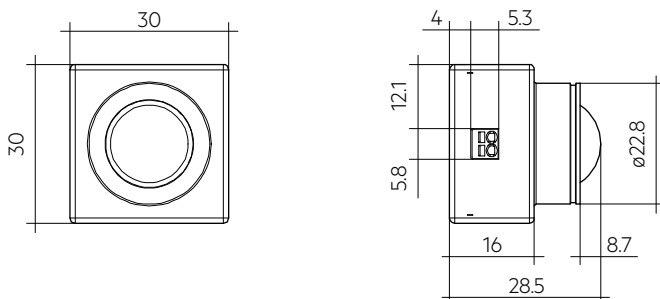
**Ordering data**

Type	Article number	Suitable for	Dimensions L x W x H	Packaging, carton	Weight per pc.
MSensor OTD SFI 30 PIR 10DP DA WH	28004440	Luminaire installation	30 x 30 x 28.5 mm	10 pc(s).	0.013 kg

**Technical data**

Sensor type	PIR sensor
Supply via	DALI cable
Supply voltage <sup>①</sup>	9.5 – 22.5 V
Current draw	6 mA from DALI
Current consumption (no LED)	max. 8 mA
Current consumption (with LED)	max. 9 mA
Starting time	30 s
Supported operating modes	0 or 128 (default)
Mounting height	5 – 10 m
Mounting hole diameter	23 mm
Housing thickness of the luminaire	0.75 – 4 mm
Detection angle for PIR detection (tagential / radial)	72° / 44°
Detection angle for light measurement	30° – 40°
Detection range for light measurement <sup>②</sup>	0.5 – 2,000 lx
Min. temperature difference between ambient temperature and detected object	± 4 °C
Ambient temperature ta	-20 ... +50 °C
tc point	60 °C
Storage temperature ts	-25 ... +60 °C
Housing material body	PC polycarbonate
Housing material lens	PE polyethylene
Housing colour body	White (similar to RAL 9016)
Housing colour lens	White
Type of protection <sup>③</sup>	Up to IP66
Impact protection degree	IK05
Guarantee (conditions at <a href="http://www.tridonic.com">www.tridonic.com</a> )	5 Year(s)

**Approval marks****Standards**

EN 61347-2-11, EN 55015, EN 61000-3-2, EN 61000-3-3, EN 61547, EN 62386-101, EN 62386-103, EN 62386-303, EN 62386-304, EN 62386-351

① Uin acc. IEC 62386-101.

② The measured value at the sensor head corresponds to approx. 3 to 6,300 lux on the surface measured.

③ Depending on the installation type up to IP66 for more details see data sheet chapter 3.7.

## 1. Standards

EN/IEC 61347-2-11:2001  
 EN 55015:2013  
 EN 61000-3-2:2014 Part 3-2  
 EN 61000-3-3:2013 Part 3-3  
 EN 61547:2009  
 EN 62386-101 Ed.2  
 EN 62386-103 Ed.1  
 EN 62386-303  
 EN 62386-304  
 EN 62386-351

### 1.1 DALI note



Sensor is only applicable for DALI-2 installations according to EN 62386-101 Ed.2.  
 The list of compatible systems is documented in chapter 5.

Following table shows the instances and which values they provide.

DALI instances	
Instance number	Explanation
0 – 2 *	Occupancy sensor DALI Part 303
3	Light sensor DALI Part 304

\* All 3 instances share the same PIR sensor.

### 1.2 D4i note

D4i luminaire-mounted control devices (part 351) = Type B

### 1.3 Glow wire test

according to EN 61347-2-11 passed for temperatures up to 850°C.

## 2. Common

This sensor is one of the new generation of Tridonic sensors. With this Sensor, the customer gets a small sized sensor for medium height applications and a protection against environmental influence up to IP66.

This sensor provides measurement of ambient light, occupancy detection via PIR sensor and a LED output for signalisation.

This sensor is created for following main applications:

Medium height buildings such as

- Factory buildings
- Storage buildings and warehouses
- Corridors, passages und Garages
- Outdoor applications

## 3. Installation

- The DALI MSensor must not be connected to the mains. It is supplied directly via the DALI power supply.
- DALI is not SELV.  
The installation instructions for mains voltage therefore apply.
- Please ensure that the detection range of the sensor lies in the lighting area of the controlled luminaires.
- Please ensure that the detection ranges of the sensors do not overlap. This may have influence to the lighting control.
- When installed at a height other than the recommended installation height, the sensor might show different characteristics. When mounted at a higher level, its sensitivity is reduced. If mounted at a lower level, its range is reduced.
- Heaters, fans, printers and copiers located in the detection zone may cause incorrect occupancy detection.
- Avoid direct illumination of the light source on the sensor including housing.
- Be sure to engage the mounting ring correctly in the mounting groove.

3.1 Wiring

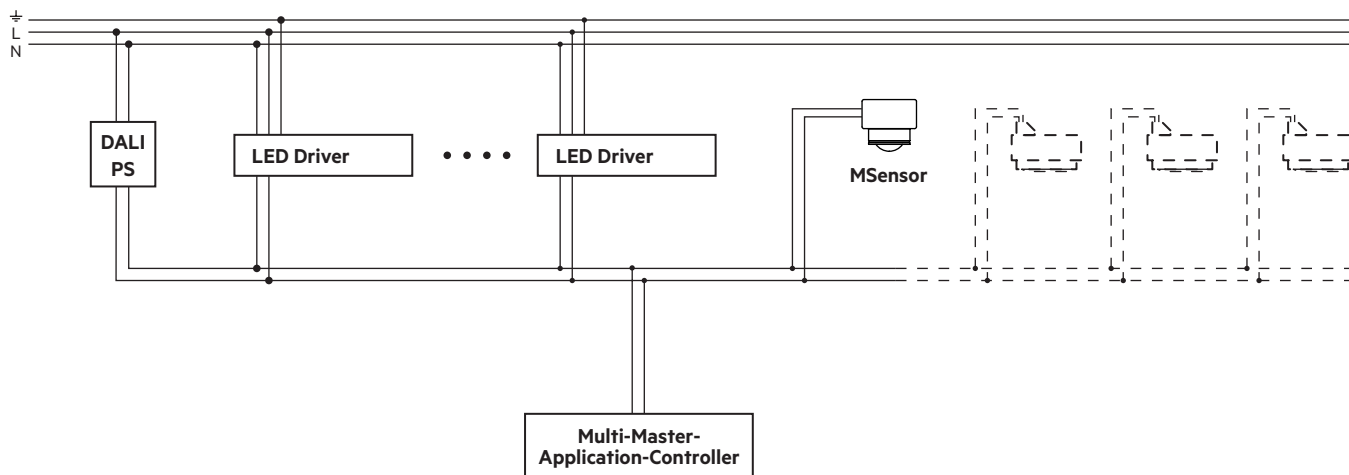

3.2 Wiring type and cross section

For wiring use stranded wire with ferrules from 0.2 to 0.5 mm<sup>2</sup> or solid wire from 0.14 to 0.5 mm<sup>2</sup>.

0.14 – 0.5 mm<sup>2</sup> solid or  
0.2 – 0.5 mm<sup>2</sup> stranded wire

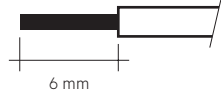

3.3 Mounting variants luminaire installation sensor:

3.3.1 Installation in luminaire

To ensure the right IP protection please read chapter 3.6 Gasket.

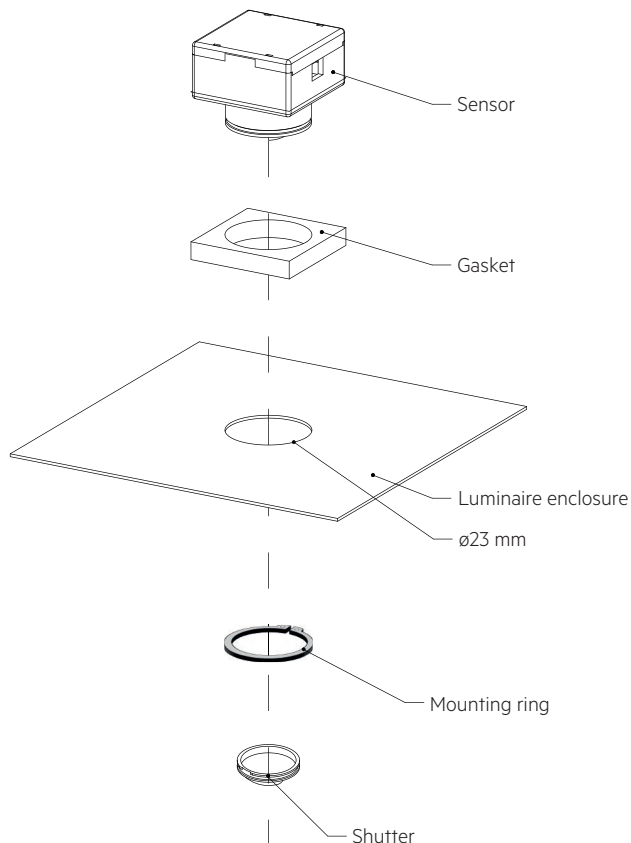

**3.4 Detection area covers**

Included in each Sensor there are three detection area covers. Each of these cover can be attached to the front of the sensor. The 180° cover reduces the detection area of PIR sensor by half. The 120° cover offers the possibility to reduce the detection area of PIR Sensor by 120° or 1/3 of its detection area. There is no influence of detection area of light measurement or IR receiver by this cover. 0° cover is made only for aesthetical reasons to give the sensor a flush surface. It is not needed for proper operation of the sensor.

	0° / 120°	180°
Type of material	PC polycarbonate	PC polycarbonate
Colour	Transparent	White
Surface finish	polished	polished

180° cover:

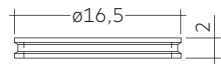

120° cover:

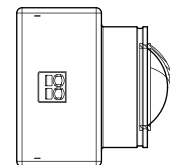
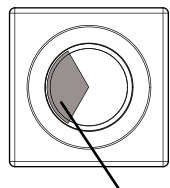
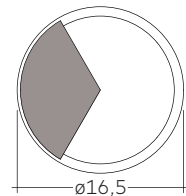
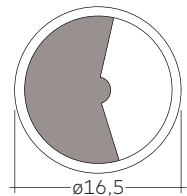
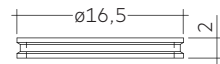

Attach the detection area cover to the sensor by inserting it into the corresponding groove at the front of the sensor.

Area which is masked, e.g. by the 120° shutter:

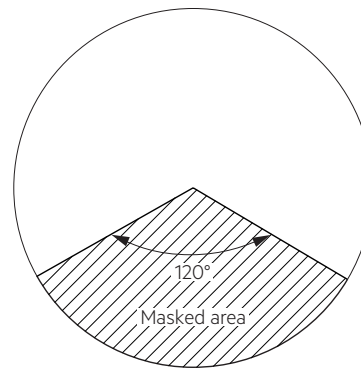
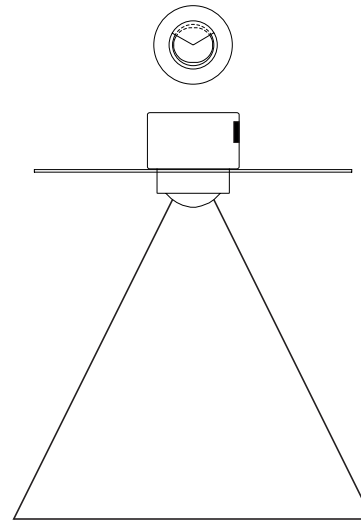

**3.5 Mounting ring**

The delivery scope of each sensor includes a black stainless steel mounting ring. This Ring allows to mount the sensor into a luminaire in an easy and visual attractive way.

**!** Be sure to engage the mounting ring correctly in the mounting groove. Excessive spreading of the mounting ring can result in permanent deformation.

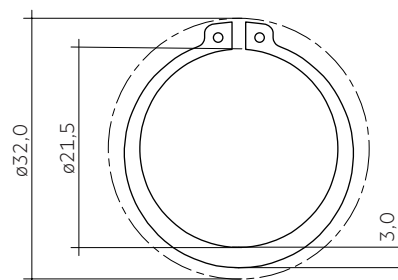

### 3.6 Gasket

To fulfill ingress protection two different gaskets are included in the sensor. The gaskets are necessary to ensure ingress protection as well as proper mounting of the sensor in luminaire.

Sensor can be inserted into luminaires with a cover size from 0.75 up to 4.0 mm.

To cover different sizes of material, three gaskets with different sizes are included.

Available size of sealing: 5 / 8 mm

According to the size of luminaire cover in certain application, one of the gaskets must be used and mounted between the front of the sensor and the luminaire housing.

It is not allowed to use a combination of e.g. two gaskets, because this will not provide the right amount of sealing and you may run in to a risk to not reach the IP66 requirements.



Use maximum possible size for your application to ensure a proper fit and protection.

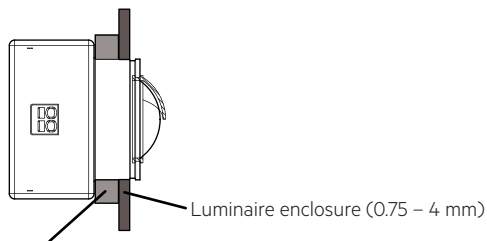

Gasket (size 5 or 8 mm)

Distance between Sensor and luminaire	Final size of gasket after assembly	Use gasket
2.5 – 4.0 mm	2.5 – 4.0 mm	5 mm
4.0 – 5.9 mm	4.0 – 5.9 mm	8 mm

### 3.8 Mounting in class II luminaire

The Sensor provides basic insulation as required by IEC 62386-101 and defined in IEC 61347-1.

If the sensor is built in to a class II luminaire which has to provide double or reinforced insulation it has to be considered that the Sensor is not a class II device. Still the Sensor can be used for such projects as the most part of the sensor is tested to fulfil the class II requirements for double or reinforced insulation. Basic insulation is illustrated in the graphic below and covers an area 2,5 mm around the terminal.

The rest of the sensor fulfils class II requirements.

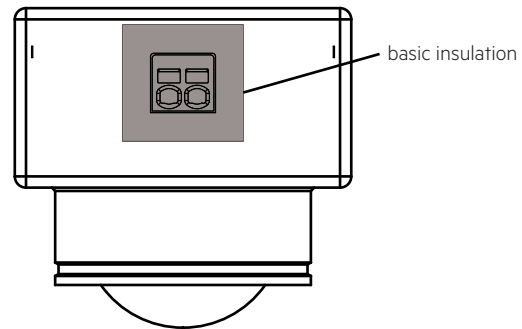

### 3.7 Ingress protection

This device contains IP-protection to use it also in applications with the need of protection against dust and water ingress. IP66 protection applies to the front of the sensor whereas the back of the sensor is IP20 rated.

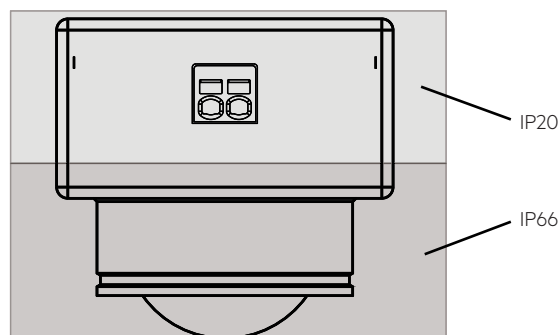

#### 4. Sensor function

##### 4.1 Occupancy / motion detection

For occupancy detection PIR technology is used. PIR Lens is made to detect moving people in working areas such as warehouses, storage buildings and similar working areas with the following performance criteria:

- Ceiling height from 5 up to 10 m
- Movement of human body (increment  $\geq 1.5$  m), no slight motion (no sitting person)
- Movement  $\geq 1.0$  m/s for mounting heights up to 7.5 m
- Movement  $\geq 1.5$  m/s for mounting heights up to 10.0 m

##### 4.2 Detection area

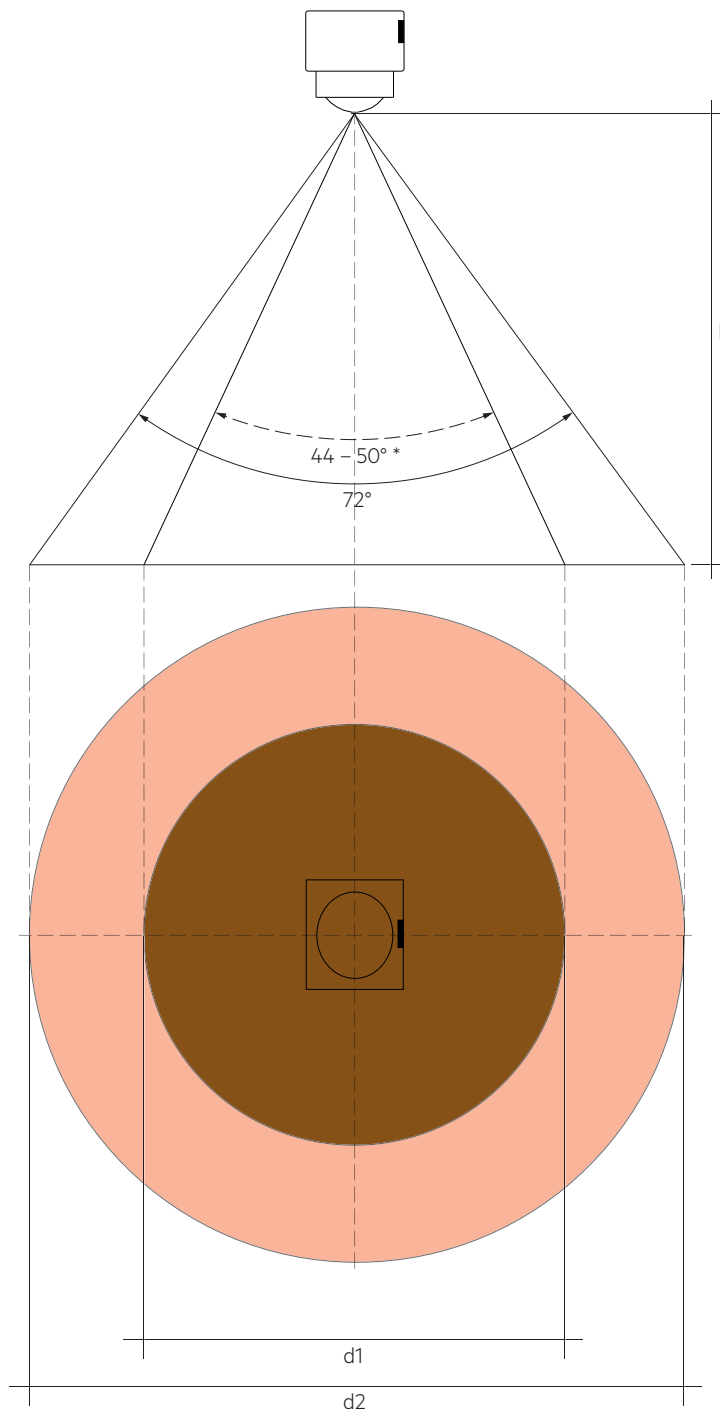

Reaction time of the sensor (time between occupancy detected and event information send to DALI Bus) is  $\leq 25$  ms.

The reaction time of the system can be extended by factors such as the amount of data on the bus, the number of connected devices or the control device used (Application Controller).

The point at which the light responds must therefore not be equated with the outer detection range.

h = Height	d1 = Radial	Radial detection angle	d2 = Tangential ( $72^\circ$ )
5 m	4.6 m	$50^\circ$	7.0 m
6 m	5.6 m	$50^\circ$	8.4 m
7 m	6.6 m	$50^\circ$	9.8 m
8 m	7.4 m	$50^\circ$	11.2 m
9 m	7.2 m	$44^\circ$	12.6 m
10 m	8.0 m	$44^\circ$	14.0 m

Schematic illustration of radial / tangential movements:

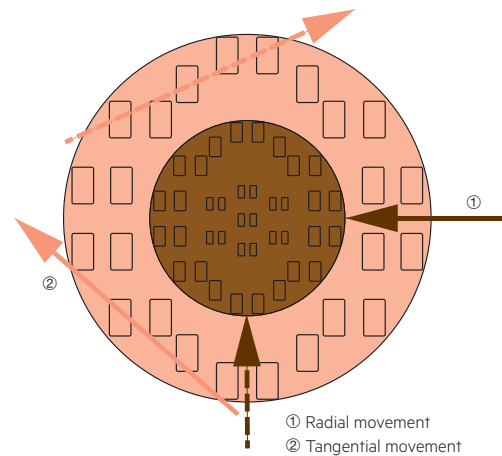

\* The detection angle for the radial movement varies with the different mounting height between  $44$  and  $50^\circ$ .

Detection example at 5 m mounting height:

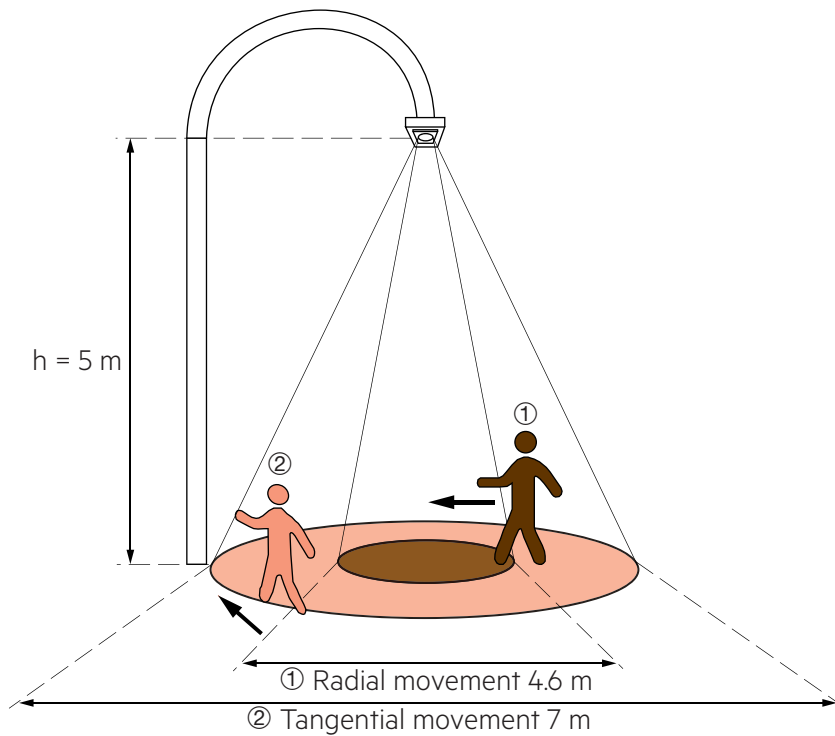

**4.3 Light measurement**

The light measurement has a cone-shaped detection area with a half angle of approximately 20° in x-direction and 15° in y-direction.

The measurement range is between 0.5 and 2000 lx. Measured at the sensor head.

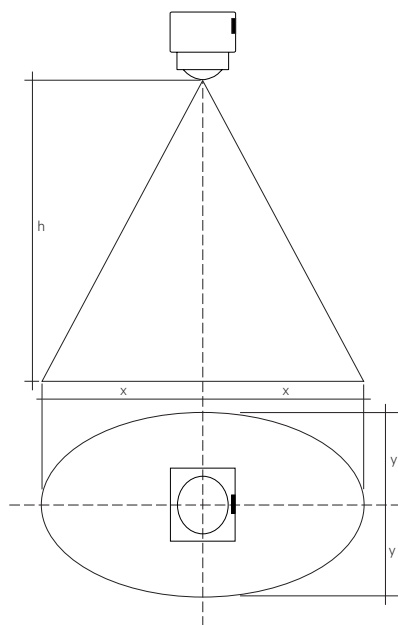

h	dx	dy
5.0 m	3.6 m	2.7 m
7.5 m	5.5 m	4.0 m
10.0 m	7.2 m	5.4 m



To be able to measure values < 5 lx in an accurate way it is needed to change integration time of light sensor to 800 ms. Integration time of light sensor is set to 100 ms by default. For values > 5 lx there is no difference in between these measurements.

**4.4 Status LED's**

There is a LED built in to indicate different status information to the user.

Event	Blinking sequence	LED Color
DALI command „identify device“	500 ms on / 500 ms off for 10 s	Red
Motion detection <sup>①</sup>	Default deactivated but can be activated by the application controller. If active, 1,000 ms on every time Motion is detected.	Red

Light measurement priority

① By default, these blinking patterns are interrupted by the light measurement, because the light measurement has a higher priority. This behavior can be changed via the application controller, i.e. it can be configured that the blinking patterns are carried out, regardless of an ongoing light measurement. Consequently, the accuracy of the light measurement will become worse, because the brightness of the LED distorts the measurement.

**4.3.1 Light value formate**

The default operating mode is 128. In this mode the user is able to choose from fixed point and floating point values for the light measurement. The default setting are floating point values. In addition to operation mode 128 also operating mode 0 is implemented. In operating mode 0 the fixed point values are supported for the light measurement values. Resolution for fixed point and floating point = 1/64 Lux

### 5. Configuration

Compatible and approved with following systems:

- Tridonic premium outdoor driver with sensorMODE
- CIS 30 RF868DA2 28002647
- CIS 30 GPS RF868 DA2 28003929
- basicDIM Wireless OTD 28004237

### 6. Miscellaneous

#### 6.1 Disposal of equipment



Return old devices in accordance with the WEEE directive to suitable recycling facilities.

#### 6.2 Additional information

Additional technical information at [www.tridonic.com](http://www.tridonic.com) → Technical Data

Guarantee conditions at [www.tridonic.com](http://www.tridonic.com) → Services

Lifetime declarations are informative and represent no warranty claim.  
No warranty if device was opened.