

CODICE PRODOTTO / PRODUCT CODE

9999/B

DESCRIZIONE / DESCRIPTION

ADATTATORE A SCOMPARSA ASIMMETRICO CON DOPPIO AGGANCIAMENTO MANUALE, A 6 CONDUTTORI (3P+N+SISTEMA DI CONTROLLO), CON SELETTORE DI FASE

ASYMMETRIC RETRACTABLE ADAPTER WITH DOUBLE MANUAL ENGAGEMENT, 6 CONDUCTORS (3P+N+CONTROL SYSTEM), WITH PHASE SELECTOR

DATI TECNICI / TECHNICAL DATA

Frequenza: 50/60Hz
Frequency:

Corrente e tensione nominale: 4A/250V 1A/50V ac FELV
Rated current and voltage:

CARATTERISTICHE / FEATURES

Materiali: Corpo in policarbonato; Contatti in lega di rame
Materials: Polycarbonate body; Copper alloy contacts

Colori disponibili: Nero RAL 9005
Available colours: Black RAL 9005

Fissaggio: Ad innesto con scatto
Fastening: Insert with click

Peso: 142,3 g
Peso:

Carico: 50N
Carico:

Massimo momento torcente: 2,5Nm
Massimo momento torcente:

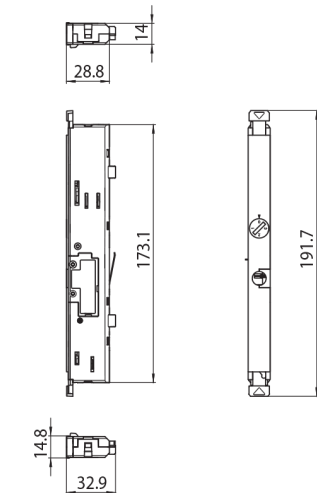

Informazioni / Information



Certificazioni / Certifications



WIRING / WIRING



Connessione a perforazione di isolante
insulation piercing connection



0,5-1

Sezione conduttore cordato e flessibile (mm²)
Section of stranded and flexible conductor (mm²)

ACCESSORI / ACCESSORIES



KIT-9909-ND/...



WIRING TOOL