

Module QLE EXC

Modules QLE excite



QLE 250x250mm EXC



QLE 270x270mm EXC



QLE 540x270mm EXC

Product description

- _ Ideal for linear and panel lights
- _ Perfectly uniform light, even if several LED modules are used together in a line
- _ Self-cooling (no additional heat sink required)
- _ Push terminals for quick and simple wiring of LED module to LED module
- _ HE ... High Efficiency, NM ... Nominal Mode, HO ... High Output
- _ Long lifetime up to 102,000 hours
- _ 5 years guarantee (conditions at <https://www.tridonic.com/en/int/services/manufacturer-guarantee-conditions>)

Optical properties

- _ Colour temperatures 3,000, 4,000 and 5,000 K
- _ Efficacy of the LED module up to 220 lm/W
- _ High colour rendering index CRI > 80
- _ Small colour tolerance (MacAdam 3) ^①
- _ Small luminous flux tolerances

Mechanical properties

- _ Module dimension 250 x 250 mm, 270 x 270 mm and 540 x 270 mm
- _ Simple installation (e.g. screws)

System solution

- _ Combine Tridonic's LED modules and dimmable drivers to achieve an outstanding system efficacy (configuration possible via <https://setbuilder.tridonic.com/>)

^① Integral measurement over the complete module.

Website

<http://www.tridonic.com/28005831>

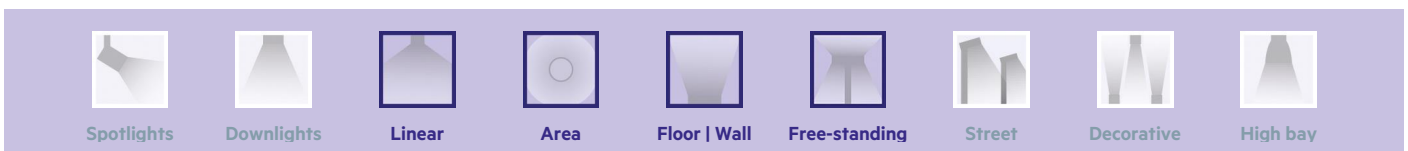

Module QLE EXC
Modules QLE excite

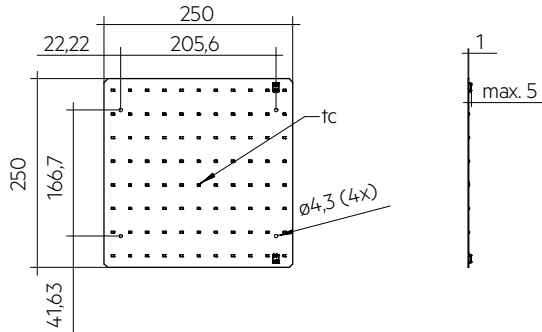

QLE 250x250mm EXC

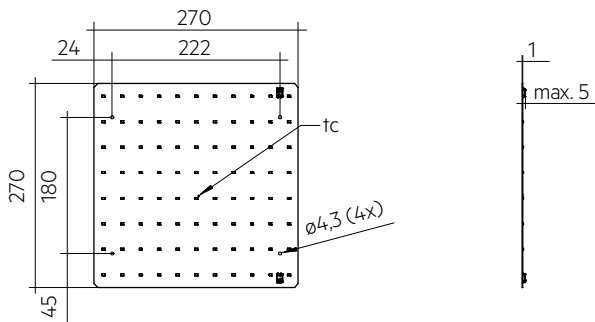

QLE 270x270mm EXC

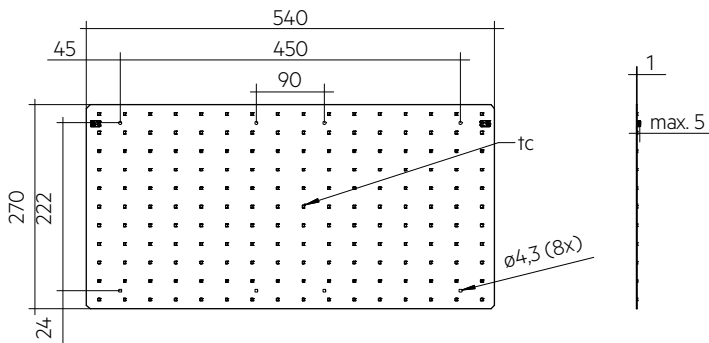

QLE 540x270mm EXC

Ordering data

Type	Article number	Colour temperature	Packaging, carton	Weight per pc.
QLE 250x250mm 1250lm 830 EXC	28005831	3,000 K	10 pc(s).	0.110 kg
QLE 250x250mm 1250lm 840 EXC	28005832	4,000 K	10 pc(s).	0.110 kg
QLE 250x250mm 1250lm 850 EXC	28005833	5,000 K	10 pc(s).	0.110 kg
QLE 270x270mm 1250lm 830 EXC	28005846	3,000 K	10 pc(s).	0.125 kg
QLE 270x270mm 1250lm 840 EXC	28005847	4,000 K	10 pc(s).	0.125 kg
QLE 270x270mm 1250lm 850 EXC	28005848	5,000 K	10 pc(s).	0.125 kg
QLE 540x270mm 2500lm 830 EXC	28005851	3,000 K	10 pc(s).	0.255 kg
QLE 540x270mm 2500lm 840 EXC	28005852	4,000 K	10 pc(s).	0.255 kg

Technical data

Beam characteristic	120°
Ambient temperature t_a	-40 ... +65 °C
t_p rated	45 °C
t_c	90 °C
I _{rated} for 250x250 / 270x270mm	200 mA
I _{rated} for 540x270mm	400 mA
I _{max} for 250x250 / 270x270mm	1,600 mA
I _{max} for 540x270mm	2,800 mA
Max. permissible LF current ripple 250x250 / 270x270mm	1,800 mA
Max. permissible LF current ripple for 540x270mm	3,100 mA
Max. permissible peak current for 250x250 / 270x270mm	2,500 mA / max. 10 ms
Max. permissible peak current for 540x270mm	4,300 mA / max. 10 ms
Max. working voltage for insulation [®]	405 V
Insulation test voltage	1.81 kV
CTI of the printed circuit board	≥ 600
Colour tolerance	3 SDCM
ESD classification	Severity level 2
Risk group (IEC 62471), 250x250, 270x270mm	RG1 (> 1554 – 1600 mA (I _{max})), RGO (≤ 1544 mA)
Risk group (IEC 62471), 540x270mm	RG0
Classification acc. to IEC 62031	Built-in
Type of protection	IP00
Lumen maintenance L70B50	102,000 h
Guarantee (conditions at www.tridonic.com)	5 Year(s)

Approval marks**Standards**

IEC 62031, IEC 62471, IEC 61000-4-2, IEC 62778, IEC 61547, UL 8750

Specific technical data

Type	Article number	Photometric code	Useful luminous flux at tp = 25 °C ^②	Expected luminous flux at tp rated ^④	Typ. forward current	Min. forward voltage at tp rated	Max. forward voltage at tp = 25 °C	Power consumption ^⑤ Pon at tp = 25 °C	Efficacy of the module at tp = 25 °C	Expected efficacy of the module at tp rated	Colour rendering index CRI
QLE 250x250 / 270x270 mm – Operating mode HE											
QLE 250x250mm 1250lm 830 EXC	28005831	830/359	-	574 lm	100 mA	27.4 V	28.7 V	-	-	203 lm/W	>80
QLE 250x250mm 1250lm 840 EXC	28005832	840/359	-	605 lm	100 mA	27.4 V	28.7 V	-	-	214 lm/W	>80
QLE 250x250mm 1250lm 850 EXC	28005833	850/359	-	605 lm	100 mA	27.4 V	28.7 V	-	-	214 lm/W	>80
QLE 270x270mm 1250lm 830 EXC	28005846	830/359	-	574 lm	100 mA	27.4 V	28.7 V	-	-	203 lm/W	>80
QLE 270x270mm 1250lm 840 EXC	28005847	840/359	-	605 lm	100 mA	27.4 V	28.7 V	-	-	214 lm/W	>80
QLE 270x270mm 1250lm 850 EXC	28005848	850/359	-	605 lm	100 mA	27.4 V	28.7 V	-	-	214 lm/W	>80
QLE 250x250 / 270x270 mm – Operating mode NM											
QLE 250x250mm 1250lm 830 EXC	28005831	830/359	1,206 lm	1,180 lm	200 mA	27.7 V	29.0 V	5.8 W	209 lm/W	207 lm/W	>80
QLE 250x250mm 1250lm 840 EXC	28005832	840/359	1,270 lm	1,243 lm	200 mA	27.7 V	29.0 V	5.8 W	220 lm/W	218 lm/W	>80
QLE 250x250mm 1250lm 850 EXC	28005833	850/359	1,270 lm	1,243 lm	200 mA	27.7 V	29.0 V	5.8 W	220 lm/W	218 lm/W	>80
QLE 270x270mm 1250lm 830 EXC	28005846	830/359	1,206 lm	1,180 lm	200 mA	27.7 V	29.0 V	5.8 W	209 lm/W	207 lm/W	>80
QLE 270x270mm 1250lm 840 EXC	28005847	840/359	1,270 lm	1,243 lm	200 mA	27.7 V	29.0 V	5.8 W	220 lm/W	218 lm/W	>80
QLE 270x270mm 1250lm 850 EXC	28005848	850/359	1,270 lm	1,243 lm	200 mA	27.7 V	29.0 V	5.8 W	220 lm/W	218 lm/W	>80
QLE 250x250 / 270x270 mm – Operating mode HO											
QLE 250x250mm 1250lm 830 EXC	28005831	830/359	-	7,845 lm	1,400 mA	30.3 V	31.6 V	-	-	180 lm/W	>80
QLE 250x250mm 1250lm 840 EXC	28005832	840/359	-	8,263 lm	1,400 mA	30.3 V	31.6 V	-	-	190 lm/W	>80
QLE 250x250mm 1250lm 850 EXC	28005833	850/359	-	8,263 lm	1,400 mA	30.3 V	31.6 V	-	-	190 lm/W	>80
QLE 270x270mm 1250lm 830 EXC	28005846	830/359	-	7,845 lm	1,400 mA	30.3 V	31.6 V	-	-	180 lm/W	>80
QLE 270x270mm 1250lm 840 EXC	28005847	840/359	-	8,263 lm	1,400 mA	30.3 V	31.6 V	-	-	190 lm/W	>80
QLE 270x270mm 1250lm 850 EXC	28005848	850/359	-	8,263 lm	1,400 mA	30.3 V	31.6 V	-	-	190 lm/W	>80
QLE 540x270mm – Operating mode HE											
QLE 540x270mm 2500lm 830 EXC	28005851	830/359	-	1,148 lm	200 mA	27.4 V	28.7 V	-	-	203 lm/W	>80
QLE 540x270mm 2500lm 840 EXC	28005852	840/359	-	1,209 lm	200 mA	27.4 V	28.7 V	-	-	214 lm/W	>80
QLE 540x270mm – Operating mode NM											
QLE 540x270mm 2500lm 830 EXC	28005851	830/359	2,411 lm	2,359 lm	400 mA	27.7 V	29.0 V	11.5 W	209 lm/W	206 lm/W	>80
QLE 540x270mm 2500lm 840 EXC	28005852	840/359	2,540 lm	2,485 lm	400 mA	27.7 V	29.0 V	11.5 W	220 lm/W	217 lm/W	>80
QLE 540x270mm – Operating mode HO											
QLE 540x270mm 2500lm 830 EXC	28005851	830/359	-	14,137 lm	2,500 mA	30.0 V	31.3 V	-	-	183 lm/W	>80
QLE 540x270mm 2500lm 840 EXC	28005852	840/359	-	14,891 lm	2,500 mA	30.0 V	31.3 V	-	-	193 lm/W	>80

② If mounted with M4 screws.

③ Tolerance of useful light flux - 0 % / + 15 %. Measurement uncertainty ± 10 %.

④ Tolerance of expected light flux - 0 % / + 15 %. Measurement uncertainty ± 10 %. Based on calculation.

⑤ Tolerance of power consumption Pon ± 10 %. Measurement uncertainty ± 5 %.

ACL CLIP 4.3mm

Accessory

**Product description**

- _ Clip for fixation of LED modules with 4.3 mm holes
- _ Fast snap on mounting (sheet thickness 0.5 – 1.0 mm for PUSH-FIX and 1 – 2 mm for PUSH-FIX Long)
- _ For drilling hole 4 mm
- _ Clip made of polycarbonate
- _ Minimum sales quantity 500 pcs.

Website

<http://www.tridonic.com/28001036>

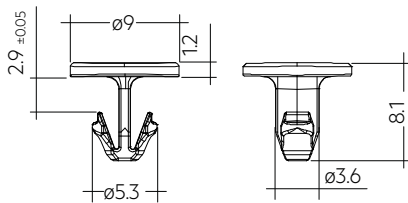
**Ordering data**

Type	Article number	Colour	Packaging, bag ^①	Weight per pc.
ACL CLIP 4.3mm PUSH-FIX	28001036	White	500 pc(s).	0.001 kg
ACL CLIP 4,3mm PUSH-FIX Long	28002314	Transparent	500 pc(s).	0.001 kg

① Minimum sales quantity 500 pcs.

1. Standards

IEC 62031
IEC 62471
IEC 62778
UL 8750 (for CLASS2 circuits and dry locations)

1.1 Photometric code

Key for photometric code, e. g. 830 / 359

1 st digit	2 nd + 3 rd digit	4 th digit	5 th digit	6 th digit
Code CRI	Colour temperature in Kelvin x 100	MacAdam initial	MacAdam after 25% of the lifetime (max.6000h)	Luminous flux after 25% of the lifetime (max.6000h)
7 70 – 79				Code Luminous flux
8 80 – 89				7 ≥ 70 %
9 ≥90				8 ≥ 80 % 9 ≥ 90 %

1.2 Energy classification

Type	Colour temperature	Forward current	Energy classification	Energy consumption
QLE 250x250mm 1250lm 830 EXC	3,000 K	200 mA	B	6 kWh / 1,000 h
QLE 250x250mm 1250lm 840 EXC	4,000 K	200 mA	B	6 kWh / 1,000 h
QLE 250x250mm 1250lm 850 EXC	5,000 K	200 mA	B	6 kWh / 1,000 h
QLE 270x270mm 1250lm 830 EXC	3,000 K	200 mA	B	6 kWh / 1,000 h
QLE 270x270mm 1250lm 840 EXC	4,000 K	200 mA	B	6 kWh / 1,000 h
QLE 270x270mm 1250lm 850 EXC	5,000 K	200 mA	B	6 kWh / 1,000 h
QLE 540x270mm 2500lm 830 EXC	3,000 K	400 mA	B	12 kWh / 1,000 h
QLE 540x270mm 2500lm 840 EXC	4,000 K	400 mA	B	12 kWh / 1,000 h

Energy label and further information at www.tridonic.com in the certificates tab of the corresponding product page and at the EPREL data base <https://eprel.ec.europa.eu/>

2. Thermal details

2.1 tc point, ambient temperature and lifetime

The temperature at tp reference point is crucial for the light output and lifetime of a LED product.

For QLE a tp temperature of 45 °C has to be complied in order to achieve an optimum between thermal requirements, light output and lifetime.

Compliance with the maximum permissible reference temperature at the tc point must be checked under operating conditions in a thermally stable state. The maximum value must be determined under worst-case conditions for the relevant application.

The tc and tp temperature of LED modules from Tridonic are measured at the same reference point.

2.2 Storage and humidity

Storage temperature	-40... +85 °C
---------------------	---------------

Operation only in non condensing environment.
Humidity during processing of the module should be between 30 to 70 %.

2.3 Thermal design and heat sink

The rated life of LED products depends to a large extent on the temperature. If the permissible temperature limits are exceeded, the life of the QLE will be greatly reduced or the QLE may be destroyed.

3. Installation / wiring

3.1 Electrical supply/choice of LED driver

QLE modules from Tridonic are not protected against overvoltages, overcurrents, overloads or short-circuit currents. Safe and reliable operation can only be guaranteed in conjunction with a LED driver which complies with the relevant standards. The use of LED driver from Tridonic in combination with QLE modules guarantees the necessary protection for safe and reliable operation.

If a LED driver other than Tridonic is used, it must provide the following protection:

- Short-circuit protection
- Overload protection
- Overtemperature protection



QLE modules must be supplied by a constant current LED driver. Operation with a constant voltage LED driver will lead to an irreversible damage of the module.

Wrong polarity can damage the QLE.

With parallel wiring tolerance-related differences in output are possible (thermal stress of the module) and can cause differences in brightness. For best homogeneity, only connect modules from one batch in parallel.

If a wire breaks or a complete module fails then the current passing through the other module increases. This may reduce its life considerably.

The max. permissible output current of the LED driver for parallel wiring is 1.8 A.

With parallel connection and a supply on one side, the Irated current must not be exceeded.

With parallel connection and supply on both sides, the forward current for the high output operating mode must not be exceeded.

QLE modules can be operated either from SELV LED drivers or from LED drivers with LV output voltage.



QLE modules are basic insulated up to 405 V (if mounted with M4 screws with head diameter of 7 mm) against ground and can be mounted directly on earthed metal parts of the luminaire. If the max. output voltage of the led control gear (also against earth) is above 405 V, an additional insulation between LED module and heat sink is required (for example by insulated thermal pads) or by a suitable luminaire construction.

At voltages > 60 V an additional protection against direct touch (test finger) to the light emitting side of the module has to be guaranteed. This is typically achieved by means of a non removable light distributor over the module.

3.2 Wiring

QLE 250x250mm / 270x270mm:

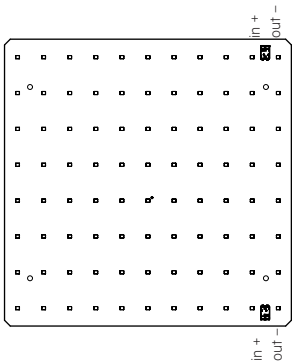

QLE 540x270mm:

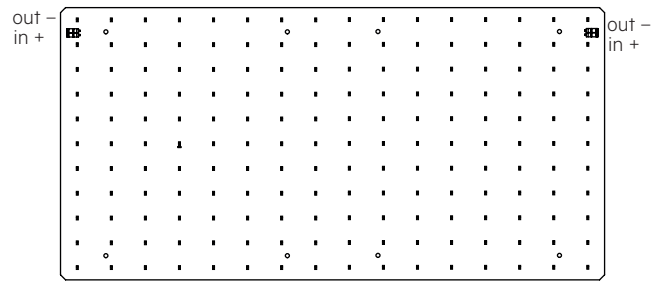

Wiring examples

QLE 250x250mm / 270x270mm serial wiring:

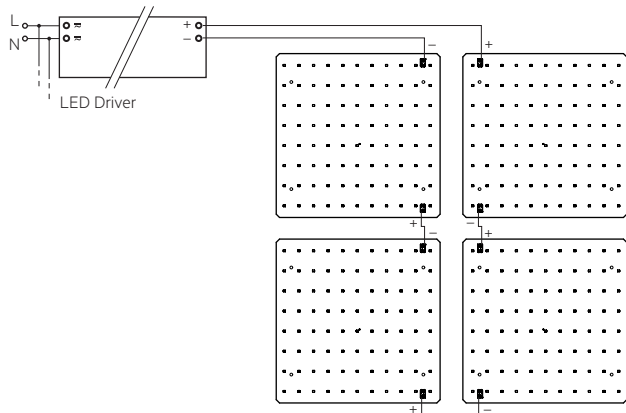

QLE 250x250mm / 270x270mm parallel wiring:

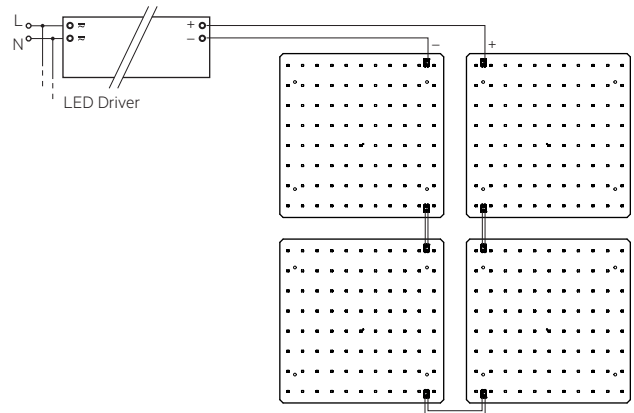

QLE 540x270mm serial wiring:

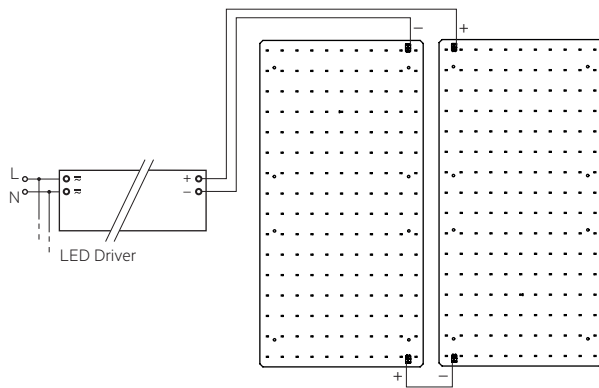

QLE 540x270mm parallel wiring:

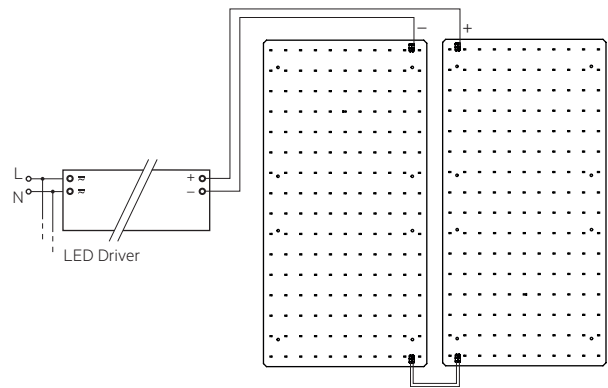

QLE 540x270mm and 270x270mm parallel wiring:

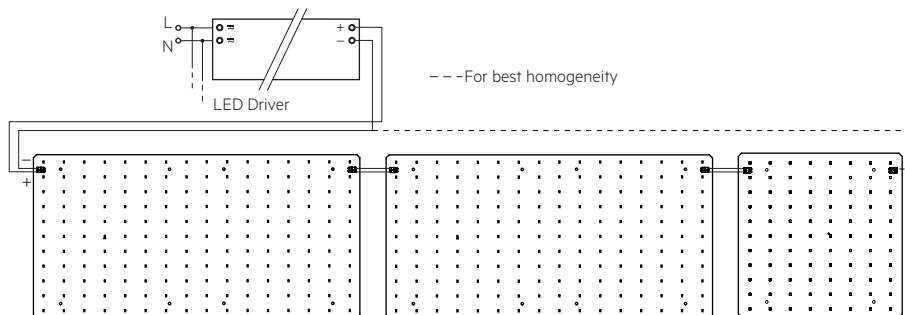

Type	Max. number with parallel wiring*
QLE 250x250 / 270x270mm 1250lm EXC	8
QLE 540x270mm 2400lm EXC	4

* with direkt chaining (without additional terminals).

3.3 Wiring type and cross section

For wiring use stranded wire with ferrules or solid wire from 0.2 to 0.75 mm².
For the push-wire connection you have to strip the insulation (8–9 mm).

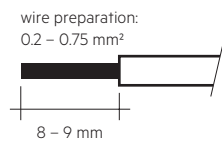

To remove the wires use a suitabel tool (e.g. Microcon release pin) or through twist and pull .

3.4 Mounting instruction



None of the components of the QLE (substrate, LED, electronic components etc.) may be exposed to tensile or compressive stresses.

Max. torque for fixing: 0.5 Nm.

The LED modules are mounted with M4 screws or ACL CLIP 4.3mm per module.



Chemical substance may harm the LED module. Chemical reactions could lead to colour shift, reduced luminous flux or a total failure of the module caused by corrosion of electrical connections.

Materials which are used in LED applications (e.g. sealings, adhesives) must not produce dissolver gas. They must not be condensation curing based, acetate curing based or contain sulfur, chlorine or phthalate.

Avoid corrosive atmosphere during usage and storage.

3.5 EOS/ESD safety guidelines



The device / module contains components that are sensitive to electrostatic discharge and may only be installed in the factory and on site if appropriate EOS/ESD protection measures have been taken. No special measures need be taken for devices/modules with enclosed casings (contact with the pc board not possible), just normal installation practice. Please note the requirements set out in the document EOS / ESD guidelines (Guideline_EOS_ESD.pdf) at: <http://www.tridonic.com/esd-protection>

4. Lifetime

4.1 Lifetime, lumen maintenance and failure rate

The light output of an LED module decreases over the lifetime, this is characterized with the L value.

L70 means that the LED module will give 70 % of its initial luminous flux.

This value is always related to the number of operation hours and therefore defines the lifetime of an LED module.

As the L value is a statistical value and the lumen maintenance may vary over the delivered LED modules.

The B value defines the amount of modules which are below the specific L value, e.g. L70B10 means 10 % of the LED modules are below 70 % of the initial luminous flux, respectively 90 % will be above 70 % of the initial value.

In addition the percentage of failed modules (fatal failure) is characterized by the C value.

4.2 Lumen maintenance for QLE

QLE 250x250mm / 270x270mm:

Forward current	tp temperature	L90 / B10	L90 / B50	L80 / B10	L80 / B50	L70 / B10	L70 / B50
100 mA	45 °C	52,000 h	53,000 h	> 102,000 h	> 102,000 h	> 102,000 h	> 102,000 h
	50 °C	52,000 h	53,000 h	> 102,000 h	> 102,000 h	> 102,000 h	> 102,000 h
	60 °C	52,000 h	53,000 h	> 102,000 h	> 102,000 h	> 102,000 h	> 102,000 h
	70 °C	52,000 h	53,000 h	> 102,000 h	> 102,000 h	> 102,000 h	> 102,000 h
	80 °C	52,000 h	53,000 h	> 102,000 h	> 102,000 h	> 102,000 h	> 102,000 h
200 mA	90 °C	39,000 h	39,000 h	79,000 h	79,000 h	> 102,000 h	> 102,000 h
	45 °C	52,000 h	53,000 h	> 102,000 h	> 102,000 h	> 102,000 h	> 102,000 h
	50 °C	52,000 h	53,000 h	> 102,000 h	> 102,000 h	> 102,000 h	> 102,000 h
	60 °C	52,000 h	53,000 h	> 102,000 h	> 102,000 h	> 102,000 h	> 102,000 h
	70 °C	52,000 h	53,000 h	> 102,000 h	> 102,000 h	> 102,000 h	> 102,000 h
1400 mA	80 °C	52,000 h	53,000 h	> 102,000 h	> 102,000 h	> 102,000 h	> 102,000 h
	90 °C	39,000 h	39,000 h	79,000 h	79,000 h	> 102,000 h	> 102,000 h
	45 °C	52,000 h	53,000 h	> 102,000 h	> 102,000 h	> 102,000 h	> 102,000 h
	50 °C	52,000 h	53,000 h	> 102,000 h	> 102,000 h	> 102,000 h	> 102,000 h
	60 °C	52,000 h	53,000 h	> 102,000 h	> 102,000 h	> 102,000 h	> 102,000 h

QLE 540x270mm:

Forward current	tp temperature	L90 / B10	L90 / B50	L80 / B10	L80 / B50	L70 / B10	L70 / B50
200 mA	45 °C	52,000 h	53,000 h	> 102,000 h	> 102,000 h	> 102,000 h	> 102,000 h
	50 °C	52,000 h	53,000 h	> 102,000 h	> 102,000 h	> 102,000 h	> 102,000 h
	60 °C	52,000 h	53,000 h	> 102,000 h	> 102,000 h	> 102,000 h	> 102,000 h
	70 °C	52,000 h	53,000 h	> 102,000 h	> 102,000 h	> 102,000 h	> 102,000 h
	80 °C	52,000 h	53,000 h	> 102,000 h	> 102,000 h	> 102,000 h	> 102,000 h
	90 °C	39,000 h	39,000 h	79,000 h	79,000 h	> 102,000 h	> 102,000 h
400 mA	45 °C	52,000 h	53,000 h	> 102,000 h	> 102,000 h	> 102,000 h	> 102,000 h
	50 °C	52,000 h	53,000 h	> 102,000 h	> 102,000 h	> 102,000 h	> 102,000 h
	60 °C	52,000 h	53,000 h	> 102,000 h	> 102,000 h	> 102,000 h	> 102,000 h
	70 °C	52,000 h	53,000 h	> 102,000 h	> 102,000 h	> 102,000 h	> 102,000 h
	80 °C	52,000 h	53,000 h	> 102,000 h	> 102,000 h	> 102,000 h	> 102,000 h
	90 °C	39,000 h	39,000 h	79,000 h	79,000 h	> 102,000 h	> 102,000 h
2500 mA	45 °C	52,000 h	53,000 h	> 102,000 h	> 102,000 h	> 102,000 h	> 102,000 h
	50 °C	52,000 h	53,000 h	> 102,000 h	> 102,000 h	> 102,000 h	> 102,000 h
	60 °C	52,000 h	53,000 h	> 102,000 h	> 102,000 h	> 102,000 h	> 102,000 h
	70 °C	52,000 h	53,000 h	> 102,000 h	> 102,000 h	> 102,000 h	> 102,000 h
	80 °C	52,000 h	53,000 h	> 102,000 h	> 102,000 h	> 102,000 h	> 102,000 h
	90 °C	39,000 h	39,000 h	79,000 h	79,000 h	> 102,000 h	> 102,000 h

L00C03 > 102k h. At tp rated, based on 10 switching cycles per day

4.3 Switching capability

100,000 cycles

Tridonic test according to IEC 62717 Cl 10.3.3

30 s on / 30 s off at Imax

5. Electrical values

5.1 Declaration of electrical parameters

Irated ... Nominal operating current the module is designed for.

I_{max} ... Max. permissible continuous operating current incl. the tolerances of the LED driver.

Max. permissible LF current ripple ... Max. output current of the LED driver incl. Tolerances and LF current ripple must not exceed this value.

Max. permissible peak current ... The max. output peak current of the LED driver must not exceed this value.

5.2 Typ. forward voltage vs. forward current at tp = 25 °C

QLE 250x250mm / 270x270mm:

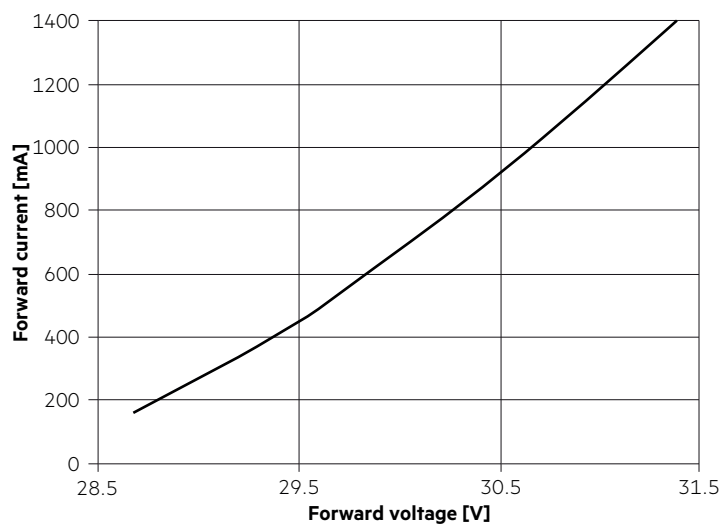

QLE 540x270mm:

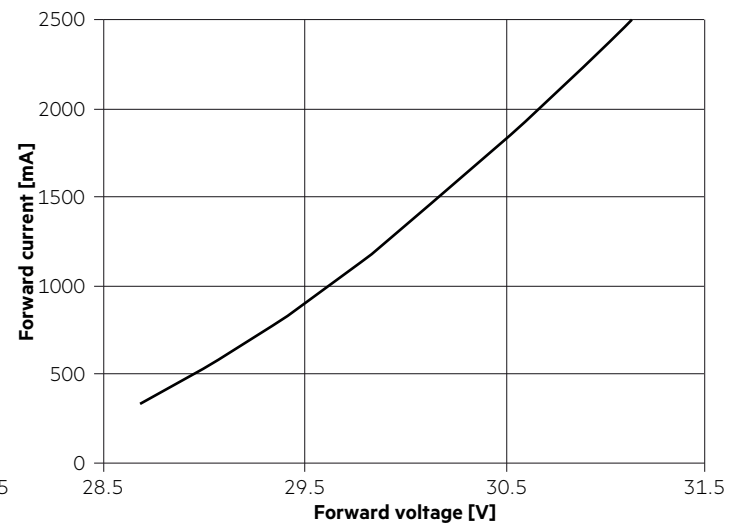

5.3 Forward voltage vs. tp temperature

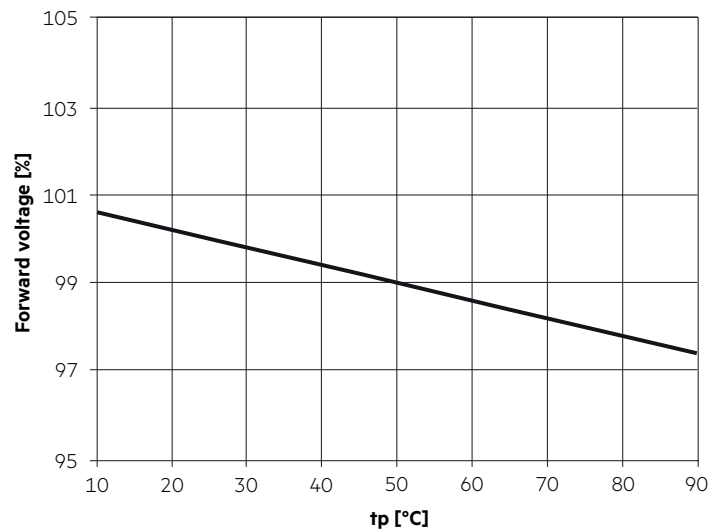

The diagrams are based on statistic values.
The real values can be different.

6. Photometric characteristics

6.1 Coordinates and tolerances according to CIE 1931

The specified colour coordinates are measured integral by a current impulse of 440 / 880 mA and a duration of 100 ms.
 The ambient temperature of the measurement is $t_a = 25^\circ\text{C}$.
 The measurement tolerance of the colour coordinates are ± 0.01 .

3,000 K, CRI 80

	x0	y0
Centre	0.4338	0.4030

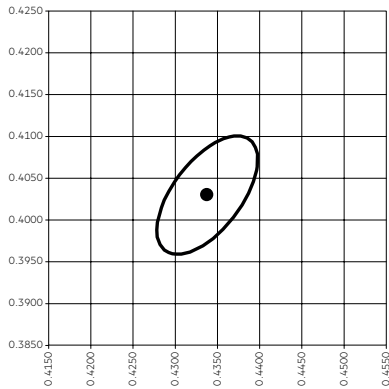

— MacAdam Ellipse: 3SDCM

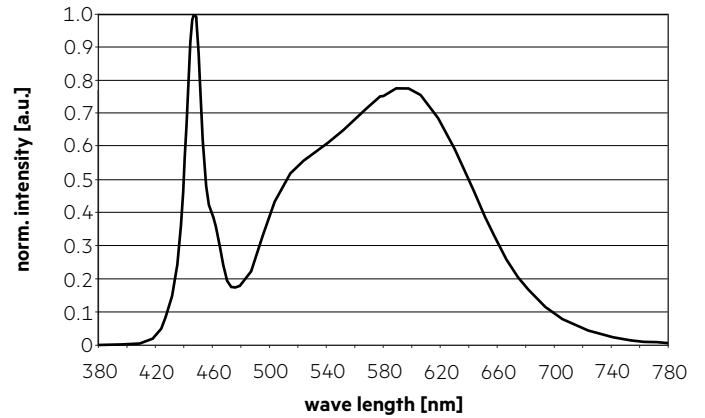

4,000 K, CRI 80

	x0	y0
Centre	0.3818	0.3797

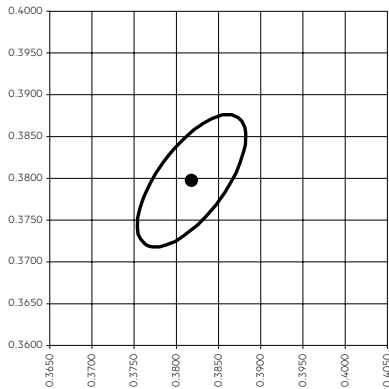

— MacAdam Ellipse: 3SDCM

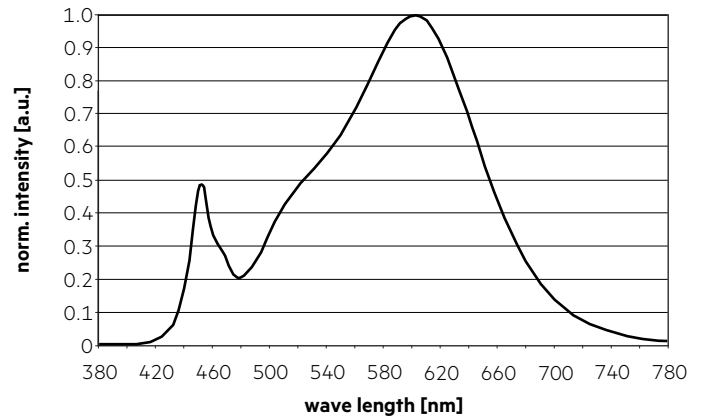

5,000 K

	x0	y0
Centre	0.3447	0.3553

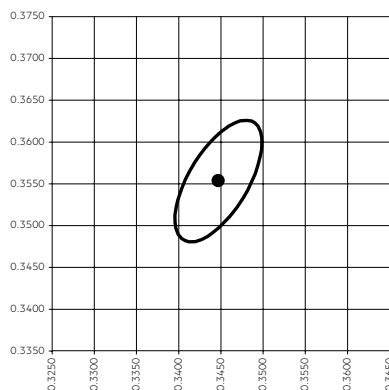

— MacAdam Ellipse: 3SDCM

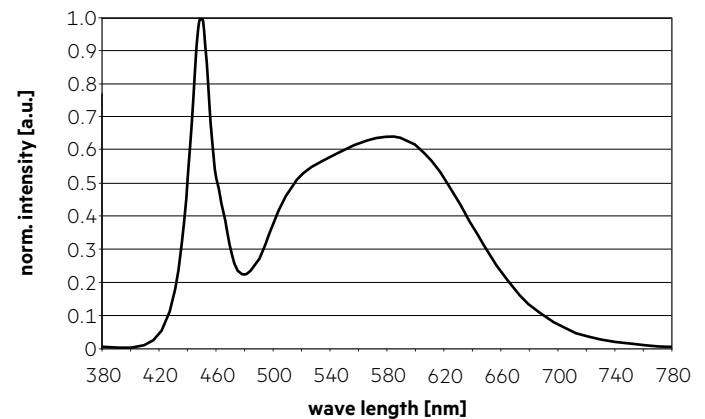

6.2 Light distribution

The optical design of the QLE product line ensures optimum homogeneity for the light distribution.

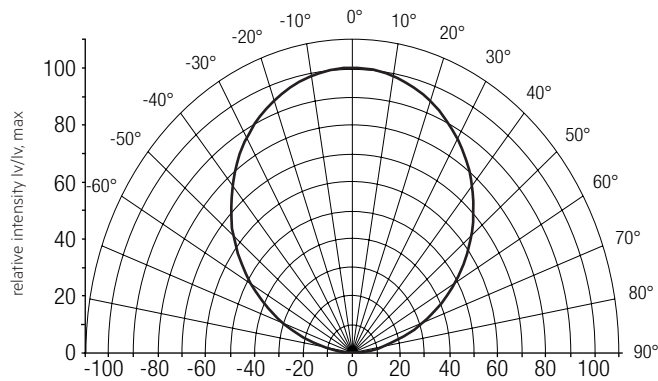

The colour temperature is measured integral over the complete module. The single LED light points can have deviations in the colour coordinates within MacAdam 5. To ensure an ideal mixture of colours and a homogeneous light distribution a suitable optic (e. g. PMMA diffuser) and a sufficient spacing between module and optic (typ. 6 cm) should be used. Designed for typical area luminaires like 600 x 600 mm troffer fittings. Special applications like illuminated ceilings must be evaluated individually.

6.3 Relative luminous flux vs. tp temperature

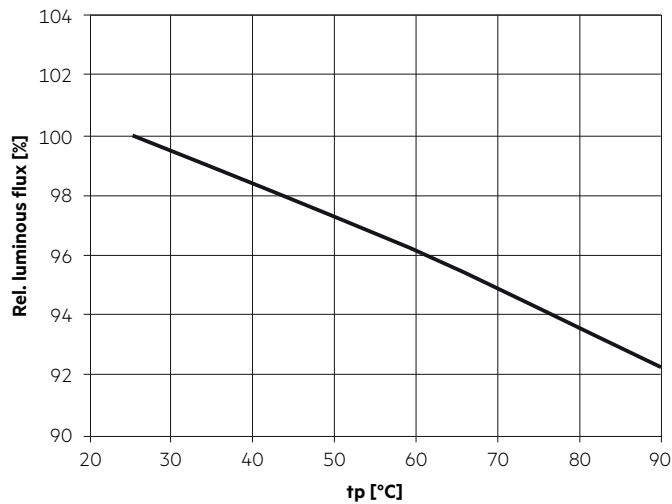

6.4 Relative luminous flux vs. operating current

QLE 250x250mm / 270x270mm:

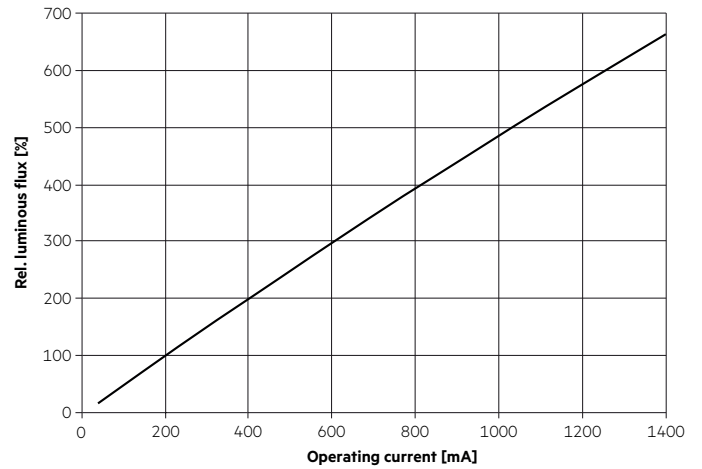

QLE 540x270mm:

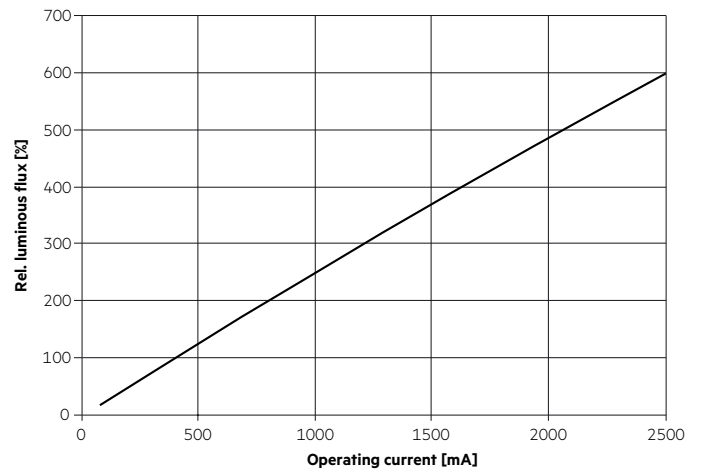

7. Miscellaneous

7.1 Additional information

Additional technical information at www.tridonic.com → Technical Data

Lifetime declarations are informative and represent no warranty claim.