

**Driver LC 18W 200-450mA flexC T SNC4**

essence in-track series (3-phase system)

**Product description**

- \_ Constant current / in-track LED driver
- \_ Compatible 3-phase system in-tracks, see data sheet chapter 3.8
- \_ For luminaires of protection class II
- \_ Temperature protection as per EN 61347-2-13 C5e
- \_ Selectable fixed output current via DIP switch 450, 400, 250 and 200 mA (pre-selected current 200 mA)
- \_ Max. output power 18 W
- \_ Up to 92 % efficiency
- \_ Nominal lifetime up to 100,000 h
- \_ 5 years guarantee (conditions at <https://www.tridonic.com/en/int/services/manufacturer-guarantee-conditions>)

**Housing properties**

- \_ Casing: polycarbonate, black, white or grey
- \_ Type of protection IP20

**Functions**

- \_ Overload protection
- \_ Short-circuit protection
- \_ No-load protection

**Typical applications**

- \_ For spot light in retail and hospitality application

**Website**

<http://www.tridonic.com/28006018>



Spotlights



Downlights



Linear



Area



Floor | Wall



Free-standing



Street



Decorative



High bay

**Driver LC 18W 200-450mA flexC T SNC4**

essence in-track series (3-phase system)

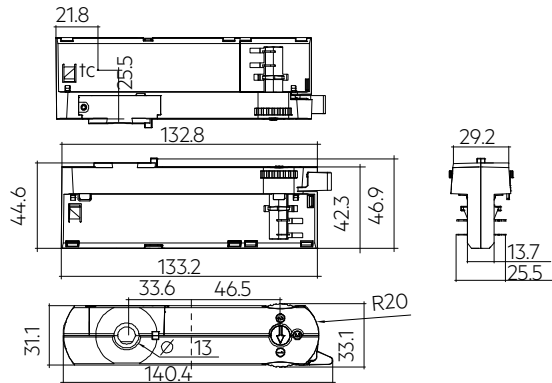
**Ordering data**

| Type                            | Article number | Colour | Packaging, carton | Packaging, low volume | Weight per pc. |
|---------------------------------|----------------|--------|-------------------|-----------------------|----------------|
| LC 18/200-450/40 flexC T-B SNC4 | 28006018       | Black  | 50 pc(s).         | 2,800 pc(s).          | 0.09 kg        |
| LC 18/200-450/40 flexC T-W SNC4 | 28006019       | White  | 50 pc(s).         | 2,800 pc(s).          | 0.09 kg        |
| LC 18/200-450/40 flexC T-G SNC4 | 28006020       | Grey   | 50 pc(s).         | 2,800 pc(s).          | 0.09 kg        |

**Technical data**

|  |                        |
|--|------------------------|
| Rated supply voltage                             | 220 – 240 V            |
| AC voltage range                                 | 198 – 264 V            |
| Max. input current (at 230 V, 50 Hz, full load)  | 0.1 A                  |
| Leakage current (at 230 V, 50 Hz, full load)     | < 450 µA               |
| Mains frequency                                  | 50 / 60 Hz             |
| Overvoltage protection                           | 320 V AC, 48 h         |
| Min. output power                                | 3 W                    |
| Max. output power                                | 18 W                   |
| Typ. efficiency (at 230 V, 50 Hz, full load)     | 92 %                   |
| λ over full operating range (max.)               | 0.95                   |
| λ over full operating range (min.)               | 0.75C                  |
| Output current tolerance <sup>①</sup>            | ± 5 %                  |
| Max. output current peak <sup>②</sup>            | 487 mA                 |
| Max. output voltage (U-OUT)                      | 59 V                   |
| THD (at 230 V, 50 Hz, full load)                 | < 20 %                 |
| Output LF current ripple (< 120 Hz) <sup>①</sup> | ± 3 %                  |
| Output P_ST_LM (at full load)                    | ≤ 1                    |
| Output SVM (at full load)                        | ≤ 0.4                  |
| Starting time (at 230 V, 50 Hz, full load)       | < 0.5 s                |
| Turn off time (at 230 V, 50 Hz, full load)       | ≤ 0.5 s                |
| Hold on time at power failure (output)           | 0 s                    |
| Ambient temperature ta (at lifetime 50,000 h)    | 35 °C                  |
| Storage temperature ts                           | -25 ... +75 °C         |
| Mains surge capability (between L - N)           | 1 kV                   |
| Mains surge capability (between L/N - PE)        | 2 kV                   |
| Surge voltage at output side (against PE)        | < 0.5 kV               |
| Lifetime   | up to 100,000 h        |
| Guarantee (conditions at www.tridonic.com)       | 5 Year(s)              |
| Dimensions L x W x H                             | 140.4 x 46.9 x 31.1 mm |

**Approval marks**

## Specific technical data

| Type                            | Output current <sup>①</sup> | Min. output voltage | Max. output voltage | Max. output power | Typ. power consumption (at 230 V, 50 Hz, full load) | Typ. current consumption (at 230 V, 50 Hz, full load) | t <sub>c</sub> point max. | Ambient temperature T <sub>a</sub> | I <sub>out</sub> select |
|---------------------------------|-----------------------------|---------------------|---------------------|-------------------|---|---|---------------------------|------------------------------------|-------------------------|
| LC 18/200-450/40 flexC T-B SNC4 | 200 mA                      | 30 V                | 40 V                | 8 W               | 9.1 W   | 49 mA   | 75 °C                     | -20 ... +35 °C                     | 1=off / 2=off           |
| LC 18/200-450/40 flexC T-B SNC4 | 250 mA                      | 30 V                | 40 V                | 10 W              | 11.0 W  | 55 mA   | 75 °C                     | -20 ... +35 °C                     | 1=off / 2=on            |
| LC 18/200-450/40 flexC T-B SNC4 | 400 mA                      | 30 V                | 40 V                | 16 W              | 17.6 W  | 81 mA   | 75 °C                     | -20 ... +35 °C                     | 1=on / 2=off            |
| LC 18/200-450/40 flexC T-B SNC4 | 450 mA                      | 30 V                | 40 V                | 18 W              | 19.6 W  | 90 mA   | 75 °C                     | -20 ... +35 °C                     | 1=on / 2=on             |
| LC 18/200-450/40 flexC T-W SNC4 | 200 mA                      | 30 V                | 40 V                | 8 W               | 9.1 W   | 49 mA   | 75 °C                     | -20 ... +35 °C                     | 1=off / 2=off           |
| LC 18/200-450/40 flexC T-W SNC4 | 250 mA                      | 30 V                | 40 V                | 10 W              | 11.0 W  | 55 mA   | 75 °C                     | -20 ... +35 °C                     | 1=off / 2=on            |
| LC 18/200-450/40 flexC T-W SNC4 | 400 mA                      | 30 V                | 40 V                | 16 W              | 17.6 W  | 81 mA   | 75 °C                     | -20 ... +35 °C                     | 1=on / 2=off            |
| LC 18/200-450/40 flexC T-W SNC4 | 450 mA                      | 30 V                | 40 V                | 18 W              | 19.6 W  | 90 mA   | 75 °C                     | -20 ... +35 °C                     | 1=on / 2=on             |
| LC 18/200-450/40 flexC T-G SNC4 | 200 mA                      | 30 V                | 40 V                | 8 W               | 9.1 W   | 49 mA   | 75 °C                     | -20 ... +35 °C                     | 1=off / 2=off           |
| LC 18/200-450/40 flexC T-G SNC4 | 250 mA                      | 30 V                | 40 V                | 10 W              | 11.0 W  | 55 mA   | 75 °C                     | -20 ... +35 °C                     | 1=off / 2=on            |
| LC 18/200-450/40 flexC T-G SNC4 | 400 mA                      | 30 V                | 40 V                | 16 W              | 17.6 W  | 81 mA   | 75 °C                     | -20 ... +35 °C                     | 1=on / 2=off            |
| LC 18/200-450/40 flexC T-G SNC4 | 450 mA                      | 30 V                | 40 V                | 18 W              | 19.6 W  | 90 mA   | 75 °C                     | -20 ... +35 °C                     | 1=on / 2=on             |

① Test result at 25 °C.

② Test result at max. current.

③ Output current is mean value.

## ACU ALU NIPPLE M10x8

Accessory

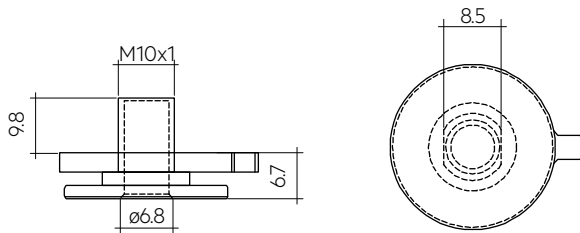
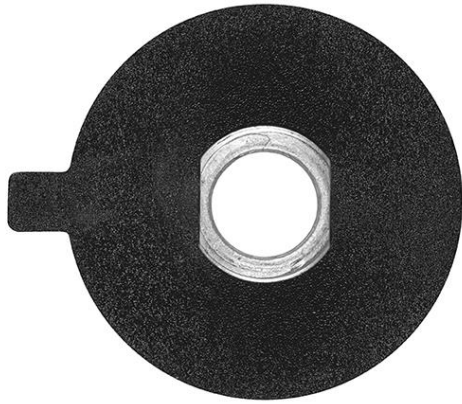
**Product description**

- \_ Optional threaded sleeve for luminaire mounting
- \_ Suitable for M10x8 mm threaded nut
- \_ We suggest to use mechanical way(screw) to assemble the nipple and track light fixture, use glue may have potential risk to change the material characteristics and destroy the plastic gasket and the nipple.

**Website**

<http://www.tridonic.com/28005589>

**Ordering data**

| Type                    | Article number | Weight per pc. |
|-------------------------|----------------|----------------|
| ACU ALU NIPPLE M10x8 BK | 28005589       | 0.005 kg       |
| ACU ALU NIPPLE M10x8 WH | 28005590       | 0.005 kg       |
| ACU ALU NIPPLE M10x8 GR | 28005591       | 0.005 kg       |

## 1. Standards

EN 55015  
 EN 61000-3-2  
 EN 61000-3-3  
 EN 61347-1  
 EN 61347-2-13  
 EN 61547  
 EN 61000-4-4  
 EN 61000-4-5

### 1.1 Glow-wire test

According to EN 61347-1 with increased temperature of 850 °C passed.

## 2. Thermal details and lifetime

### 2.1 Expected lifetime

#### Expected lifetime

| Type                          | $t_a$    | 25 °C       | 35 °C      |
|-------------------------------|----------|-------------|------------|
| LC 18/200-450/40 flexC T SNC4 | Lifetime | > 100,000 h | > 50,000 h |

The LED drivers are designed for a lifetime stated above under reference conditions and with a failure probability of less than 10 %.

Temperatures were measured with Tracktype PRO-310 from manufacturer powergear. Temperatures can deviate with tracks from other manufacturers.

## 3. Installation / wiring

### 3.1 Circuit diagram

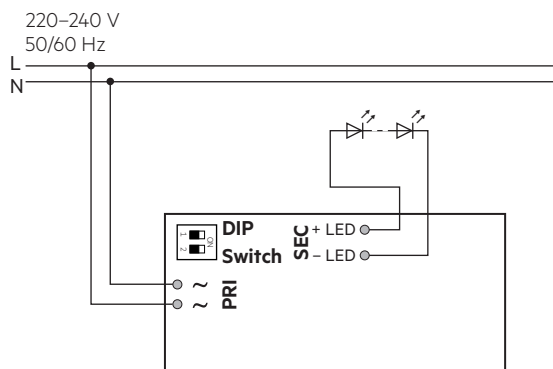

### 3.2 Wiring type and cross section

For wiring use stranded wire with ferrules or solid wire from 0.5–1.5 mm<sup>2</sup>. Strip 8–9 mm of insulation from the cables to ensure perfect operation of the push-wire terminals.

Use one wire for each terminal connector only.

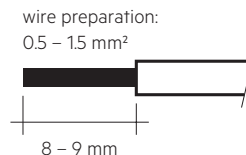

### 3.3 Release of the wiring

Press down the “push button” and remove the cable from front.

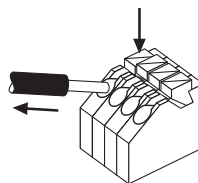

### 3.4 Fixing conditions

Dry, acidfree, oilfree, fatfree. It is not allowed to exceed the maximum ambient temperature ( $t_a$ ) stated on the device.

### 3.5 Wiring guidelines

- All connections must be kept as short as possible to ensure good EMI behaviour.
- Max. length of output wires is 20 cm.
- Secondary switching is not permitted.
- Incorrect wiring can damage LED modules.
- To avoid damage of the Driver, the wiring must be protected against short circuits to earth (sharp edged metal parts, metal cable clips, louver, etc.).

### 3.6 Replace LED module

1. Mains off
2. Remove LED module
3. Wait for 30 seconds
4. Connect LED module again

Hot plug-in or secondary switching of LEDs is not permitted and may cause a very high current to the LEDs.

### 3.7 Mounting luminaire

Max. allowed weight of complete luminaire: 5 kg (50 N)

### 3.8 Compatible tracks

Subject to be changed without notice.

| Manufacturer | Type   | System | Intrack casing colour |
|--------------|--|--------|-----------------------|
| Global       | XTS 4&XTSF 4   | 3P     | Black, white, grey    |
| Stucchi      | 9000-.../...-ST, 9000A-.../...-ST, 9000-.../...-ST15 9000-.../...-R. | 3P     | Black, white, grey    |
| Eutrac       | 2510x  | 3P     | Black, white, grey    |
| Unipro       | T32B   | 3P     | Black, white, grey    |
| Lvela        | 7501   | 3P     | Black, white, grey    |

Tests have been done with in-tracks taken from the market in the first half of 2020.



Tridonic has no control or responsibility on any future or past possible changes made by different manufactures that could affect the compatibility between tracks and adapters.

### 3.9 Adapter mounting into the track

Insert the adapter into the track, so that the mechanical key (A) in the adaptor matches the groove (B) in the track. Rotate of about 90° the lever of the cam (C) until it reaches the locking position. To open rotate the lever the opposite direction.

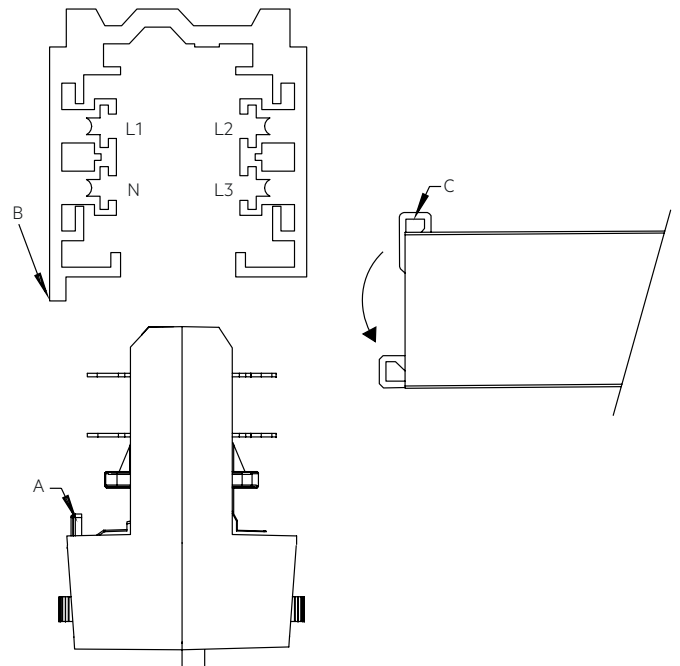
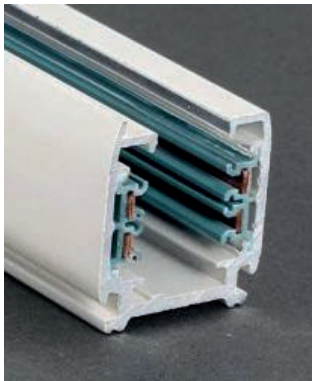

### 3.10 Phase selection

When the track is connected to a three-phase system it is possible to select the phase (L1, L2 or L3) to distribute the single luminaires in the system, by means of the proper selector of the adaptor.

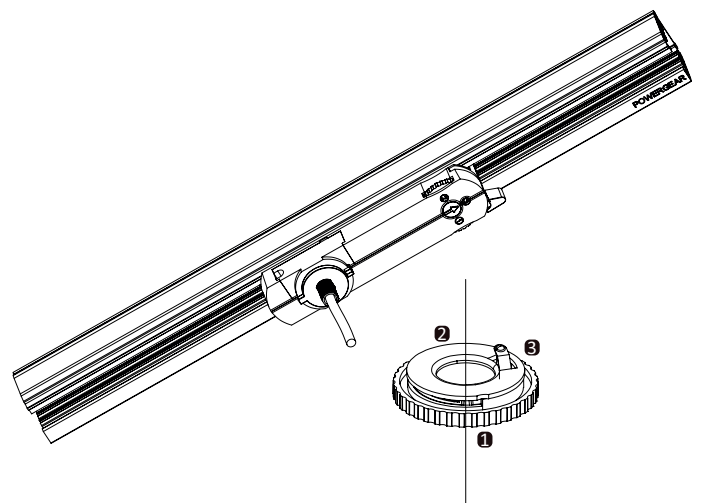

3.1.1 Current setting



Set the current by DIP switch after mains off.  
Use of DIP switch only after mains off.

**200 mA:** Switch 1 = Off, Switch 2 = Off

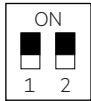

**250 mA:** Switch 1 = Off, Switch 2 = On



**400 mA:** Switch 1 = On, Switch 2 = Off

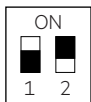

**450 mA:** Switch 1 = On, Switch 2 = On

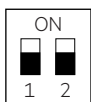

4. Electrical values

4.1 Efficiency vs load

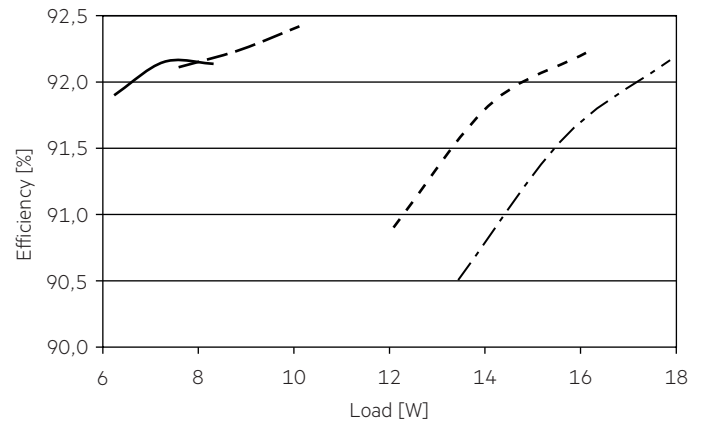

4.2 Power factor vs load

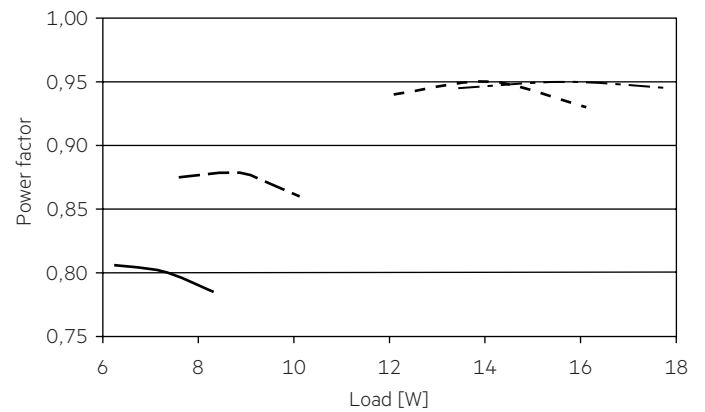

4.3 THD vs load

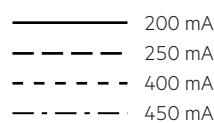
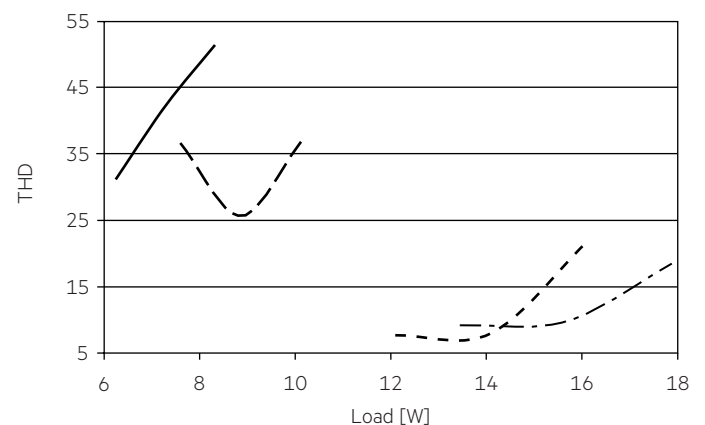

#### 4.6 Maximum loading of automatic circuit breakers in relation to inrush current

| Automatic circuit breaker type       | C10                 | C13                 | C16                 | C20                 | B10                 | B13                 | B16                 | B20                 | Inrush current   |        |
|--------------------------------------|---------------------|---------------------|---------------------|---------------------|---------------------|---------------------|---------------------|---------------------|------------------|--------|
| Installation Ø                       | 1.5 mm <sup>2</sup> | 1.5 mm <sup>2</sup> | 2.5 mm <sup>2</sup> | 2.5 mm <sup>2</sup> | 1.5 mm <sup>2</sup> | 1.5 mm <sup>2</sup> | 2.5 mm <sup>2</sup> | 2.5 mm <sup>2</sup> | I <sub>max</sub> | Time   |
| <b>LC 18/200-450/40 flexC T SNC4</b> | 55                  | 71                  | 88                  | 110                 | 34                  | 44                  | 55                  | 68                  | 10 A             | 114 µs |

These are max. values calculated out of inrush current! Please consider not to exceed the maximum rated continuous current of the circuit breaker. Calculation uses typical values from ABB series S200 as a reference. Actual values may differ due to used circuit breaker types and installation environment.

#### 4.7 Harmonic distortion in the mains supply (at 230 V / 50 Hz and full load) in %

|                                      | THD  | 3.   | 5.   | 7.   | 9.   | 11.  |
|--------------------------------------|------|------|------|------|------|------|
| <b>LC 18/200-450/40 flexC T SNC4</b> | < 20 | < 20 | < 25 | < 20 | < 20 | < 20 |

## 5. Functions

### 5.1 Short-circuit behaviour

In case of a short circuit on the secondary side (LED) the LED driver switches off. After elimination of the short-circuit fault the LED driver will recover automatically.

### 5.2 No-load operation

The LED driver works in burst working mode to provide a constant output voltage regulation which allows the application to be able to work safely when LED string opens due to a failure.

### 5.3 Overload protection

If the maximum load is exceeded by a defined internal limit, the LED driver will protect itself and LED may flicker. After elimination of the overload the nominal operation will recover automatically.

## 6. Miscellaneous

### 6.1 Insulation and electric strength testing of luminaires

Electronic devices can be damaged by high voltage. This has to be considered during the routine testing of the luminaires in production.

According to IEC 60598-1 Annex Q (informative only!) or ENEC 303-Annex A, each luminaire should be submitted to an insulation test with 500 V<sub>DC</sub> for 1 second. This test voltage should be connected between the interconnected phase and neutral terminals and the earth terminal. The insulation resistance must be at least 2 MΩ.

As an alternative, IEC 60598-1 Annex Q describes a test of the electrical strength with 1500 V<sub>AC</sub> (or 1.414 x 1500 V<sub>DC</sub>). To avoid damage to the electronic devices this test must not be conducted.

### 6.2 Conditions of use and storage

Humidity: 10 % up to max. 95 %, not condensed (max. 56 days/year at 85 %)

Storage temperature: -25 °C up to max. +75 °C

The devices have to be within the specified temperature range (t<sub>a</sub>) before they can be operated.

### 6.3 Maximum number of switching cycles

All LED driver are tested with 50,000 switching cycles.

### 6.4 Additional information

Additional technical information at [www.tridonic.com](http://www.tridonic.com) → Technical Data

Lifetime declarations are informative and represent no warranty claim. No warranty if device was opened.