

DALI-2 IoT4

Datasheet

DALI-LAN Interface

Central control module and
DALI-LAN Interface
DALI Cockpit Interface
suitable for DALI and DALI-2



Standard Version: Art.Nr. 22176625

Art.Nr. 22176625-PS

Node-RED Version: Art.Nr. 22176625-NR

Art.Nr. 22176625-PS-NR

DALI-2 IoT4 Central Control Device & Interface

Overview

- Independent lighting control for up to 256 DALI control gear on 4 DALI lines
- Version with integrated DALI bus power supply (125mA/line, ~30 DALI gears/line)
- Interface module to connect a DALI network and a LAN network
- IoT (LAN) interface to DALI: addressing, status queries, monitoring, etc. of DALI ballasts
- PF Software DALI Cockpit for simple configuration of DALI devices on the DALI lines
- Modbus TCP interface for integration in central control units
- RESTful API endpoints and WebSocket with JSON syntax, encrypted (optionally unencrypted) for custom integrations with local network-based third-party systems.
- Connect the 4 DALI lines by frame forwarding: Trigger-Actions
(*configuration via DALI Cockpit coming soon*)
- Additional centralized functionality (configuration via DALI Cockpit coming soon)
 - DALI frame forwarding between lines (trigger actions)
 - Configurable time switch / scheduler
 - sequences
 - Circadian schedules
- Node-RED support: Lunatone Node-RED module for simple integration in Node-RED automations (supported from firmware version 1.7.0 on)
- DALI-2 IoT Node-RED version available: DALI-2 IoT4 with integrated Node-RED server (Art. No. 22176625-NR)
- DIN rail mounting (2DU)
- Supply 24VDC (e.g.: with 24V / 300mA Art.Nr. 24166012-24HS)



Specification, Characteristics

type	DALI-2 IoT4	DALI-2 IoT4 PS
article number	22176625	22176625-PS
GTIN	22176625-NR	22176625-PS-NR
	9010342014444	9010342014482

electrical data		
power supply	24V-48V DC	
power consumption	@ 24V: 15mA @ 48V: 10mA	at full DALI bus load (4x 120mA): @24V: ca. 400mA @48V: ca. 200mA
Ethernet	1 x Ethernet 10/100Base-T, electrically isolated, isolation voltage, 1500V AC, RJ45-connector	
DALI	4x DALI, electrically isolated	

output DA0, DA0 / DA1, DA1 / DA2,DA2 / DA3, DA3		
output type	DALI control output	DALI control output and DALI power supply
number of outputs	4	4
marking output terminals	DA, DA	DA+, DA-
output voltage range	9,5Vdc ... 22,5Vdc (according to IEC62386)	12Vdc ... 20,5Vdc
power consumption DALI	2mA	-
DALI supply current	-	120mA
guaranteed DALI supply current	-	120mA
max. DALI supply current	-	250mA

general data	
mounting	DIN rail (2 DU)
Dimensions (L x W x H)	98 x 36 x 56 mm (see page 4)
protection degree housing	IP40
protection degree terminals	IP20

environmental conditions	
storage and transportation temperature	-20°C ... +75°C
operational ambient temperature	-5°C ... +45°C
rel. humidity, not condensing	15% ... 90%

terminals	
connection type	screw connector
wire size: solid core	0,5 ... 2,5 mm2 (AWG20 ... AWG14)
wire size: fine wired	0,5 ... 2,5 mm2 (AWG20 ... AWG14)
wire size: using wire end ferrule	0,25 ... 1,5 mm2
stripping length	7 mm / 0,27 inch
tightening torque	0,5 Nm
release of wire	open screw

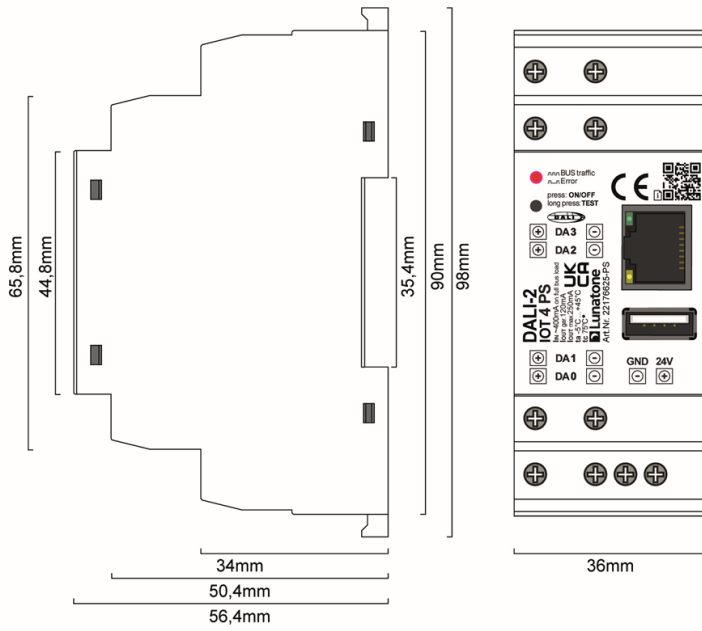

dimensions
DALI-2 IoT4 PS and DALI-2 IoT4 PS Node RED

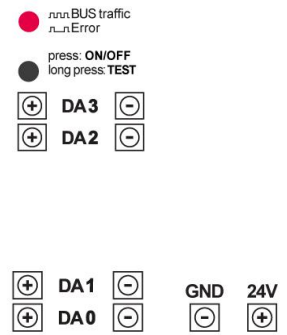

connection plan
DALI-2 IoT4 PS and DALI-2 IoT4 PS Node RED

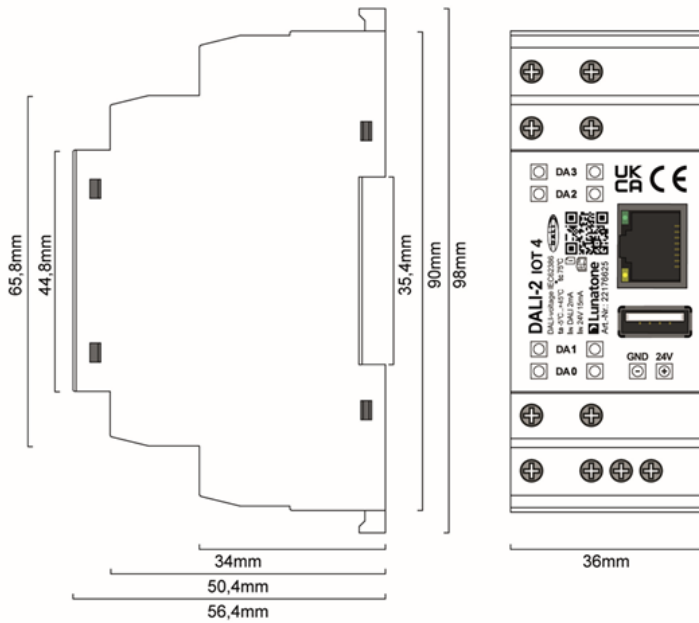

dimesions
DALI-2 IoT4 und DALI-2 IoT4 Node RED

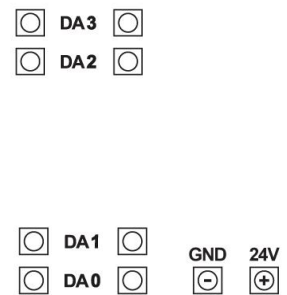

connection plan
DALI-2 IoT4 und DALI-2 IoT4 Node RED

Typical Application

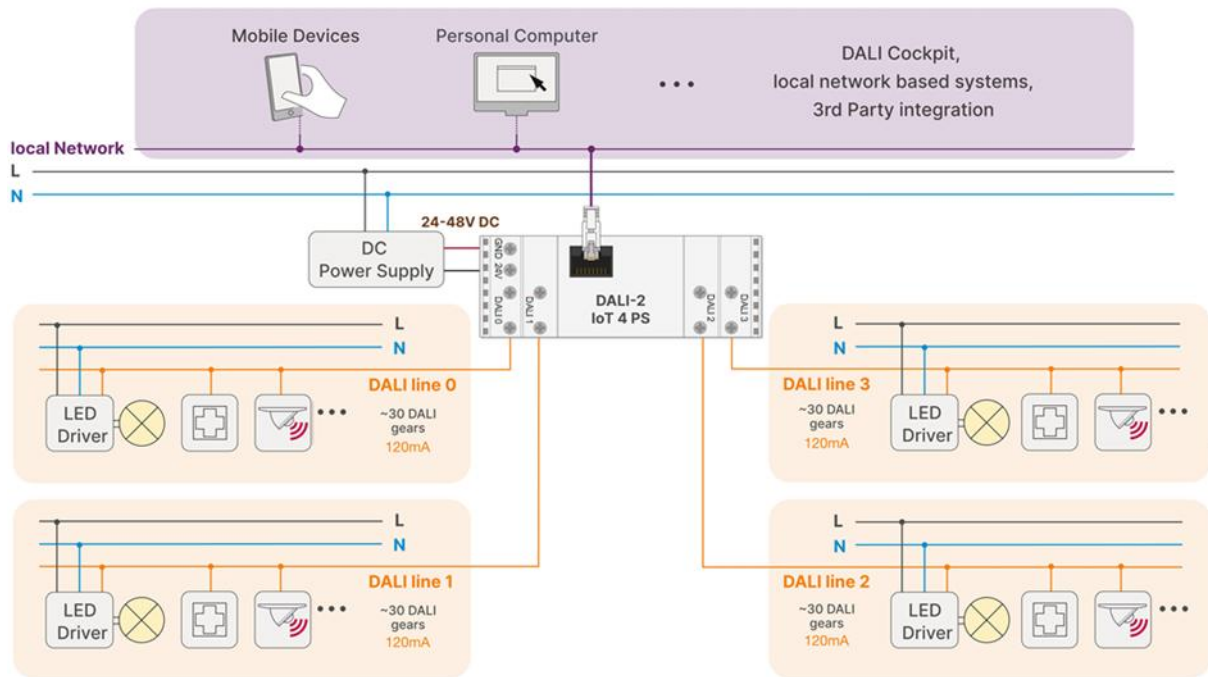

typical application: DALI-2 IoT4 PS, 120mA bus supply per DALI line. An extension of the bus supply is possible with [DALI Repeater](#) / [DALI Expander](#), or DALI-2 IoT4 with a separate DALI PS per DALI line; any lines 0-3 can be used/connected.

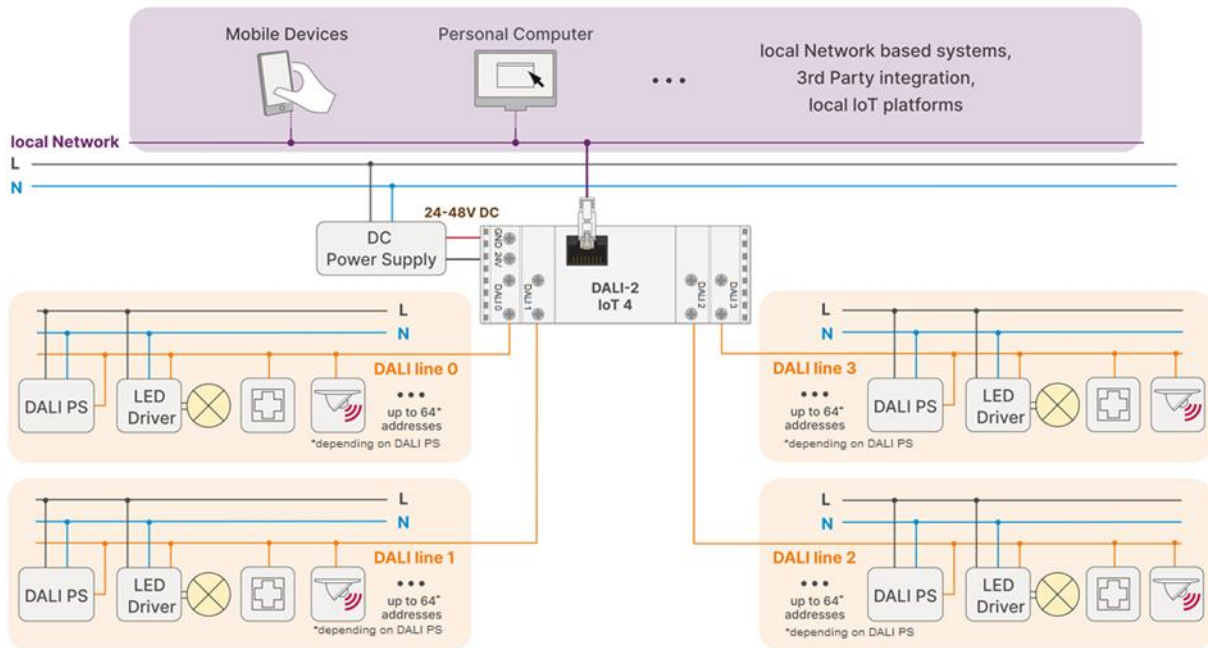

typical application: DALI-2 IoT4, a DALI power supply per DALI line is required; any lines 0-3 can be used/connected.

Installation

- The DALI-2 IoT4 requires a 24 V supply, which is connected to the terminals provided for this purpose (suitable power supply unit: [PS 24V, 1000mA, article nr.: 24166173-24HS](#)).
- **DALI-2 IoT4 PS (22176625-PS):**
 - The 4 DALI outputs (DA0-DA4) each have an integrated DALI PS (120mA per DALI line).
 - No additional DALI power supply may be connected to the DALI outputs. If additional DALI gears are required on the DALI lines, a [DALI Repeater](#) or [DALI Expander](#) can be added, alternatively the DALI-2 IoT4 with external DALI PS can be used instead.
 - The polarity of the output voltage is marked on the housing (DA+, DA-)
- **DALI-2 IoT4 (22176625):**
 - The supply of the 4 DALI circuits (DA0-DA4) must be ensured by a suitable DALI bus power supply each (e.g. [DALI PS article nr.: 24033444](#)).
 - The connection to the DALI terminals can be made regardless of polarity. The bus input is protected against overvoltage (mains voltage).
- The wiring should be carried out as a permanent installation in a dry and clean environment.
- Installation may only be carried out in a voltage-free state of the system and by qualified specialists.
- National regulations for setting up electrical systems must be followed.
- The DALI wiring can be realized with standard low-voltage installation material. No special cables are required.
- Only 1 wire may be connected to each terminal. When using double wire end ferrules, the connection capacity of the terminal must be considered.
- The DALI-line must not be connected to the mains or extra low voltage systems
- Wiring topology of the DALI-line: line, tree, star



Attention: The DALI-signal is not classified as SELV circuit (Safety Extra Low Voltage). Therefore, the installation regulations for low voltage apply.



Pay attention to the cable cross-section: the voltage drop on the DALI line must not exceed 2V at maximum length (300m) and maximum bus load (250mA).

Functionality

The DALI-2 IoT4 is a control unit with control functionality for the integrated 4 DALI lines as well as an interface for connecting the DALI system with smart devices via the Internet of Things (IoT) over the local network.

Available DALI functionality:

- Timer (recall DALI commands by date and time)
- Circadian control
- Sequencer (sequences of DALI commands)
- Trigger Actions to link the 4 DALI lines. (Forwarding commands from one line to another)

- DALI Cockpit interface for configuring the DALI devices on the 4 DALI buses

The DALI-2 IoT4 offers the following interfaces:

- RestFul API
- Websocket Interface
- Modbus TCP Server (only for DALI commands)

The USB port on the device does currently not support any functionality.

Network Connection

The DALI-2 IoT is configured to automatically obtain an IP address using the DHCP protocol. If the DALI-2 IoT4 is unable to reach a DHCP server (e.g. when the DALI-2 IoT4 is directly connected to a PC) it falls back to the static IP address 169.254.0.1, and the subnet mask 255.255.0.0. after 1min.

If the DALI-2 IoT4 device is in a network and receives its IP address via DHCP, the IP-address can be determined using a "Discovery" protocol: The DALI-2 IoT listens to UDP packets on port 5555, containing discovery and reacts by sending back {"type": "dali-2-iot4"}. For detailed information see the DALI-2 IoT-API manual: [DALI IOT API documentation](#)

Network settings can be changed via the API documentation (http://<IP_ADDRESS of the DALI-2 IoT>/docs).

DALI Cockpit

The DALI-2 IoT4 Gateway can be used as an Interface to the Windows desktop application [DALI Cockpit](#) (Cockpit Version 1.38 or higher), for configuration of the DALI devices on the connected DALI bus.

The Windows PC from which the DALI Cockpit is used and the DALI-2 IoT4 need to be in the same local network.

To select the DALI-2 IoT4 as the DALI bus interface in the DALI Cockpit: choose the option "Network" and "DALI-2 Display, DALI-2 IoT, DALI-2 WLAN" and specify the device's IP address. If the IP address is not known, the network can be searched for devices using the button next to the IP address input field:

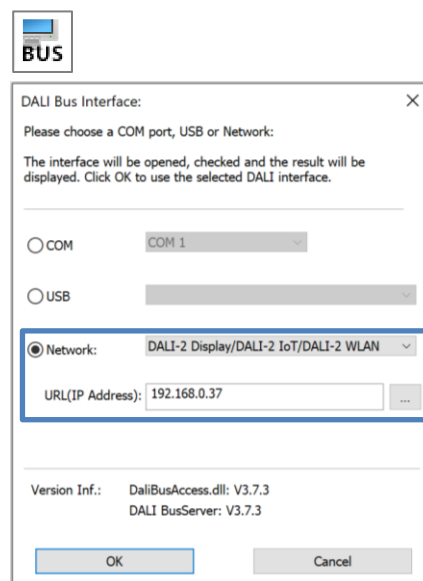

By selection the DALI-2 IoT4 is listed as an interface in the device list and can be used for addressing, monitoring and controlling the DALI bus.

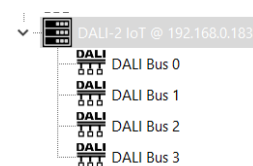

[DALI Cockpit Manual](#)

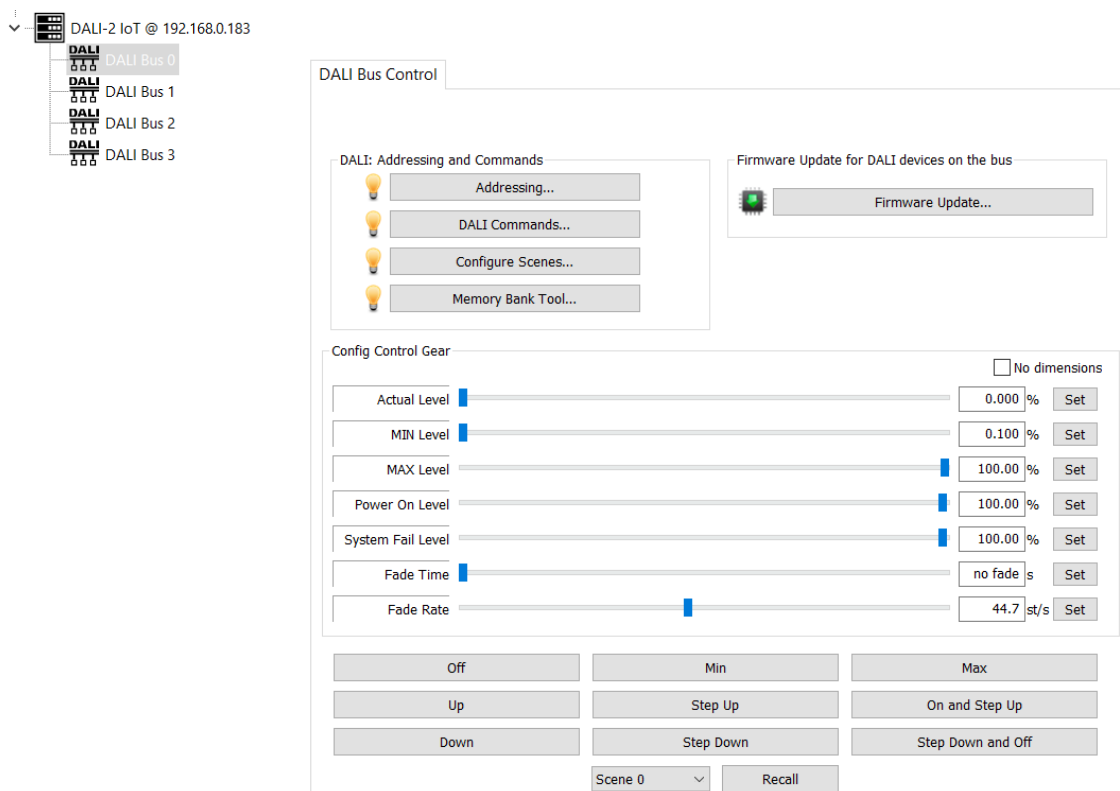

Figure 1 DALI Cockpit control and addressing per DALI line

DALI Control functionality

With the RestfulAPI, timer, sequencer, circadian control and trigger actions of the device can be set.

Alternatively, in one of the next DALI Cockpit releases, the settings can also be made via the DALI Cockpit.

Crossline functions - "Trigger Actions"

Links between the 4 lines can be created with the option "Trigger Actions".

Thereby DALI control commands are forwarded to the defined addresses unidirectionally or bidirectionally between the lines.

This means that the address range of a button can be extended to other lines via forwarding. Broadcast, groups or addresses can be selected as a range.

The Trigger-Action function can also be used to implement more specific requirements, such as cross-bus control and synchronization of sensors.

Scheduler

The DALI-2 IoT4 has a programmable calendar function. The following parameters can be set for a scheduler entry:

- Name for the entry
- Effective range (zones and individual addresses, groups or broadcast on the individual lines, and across lines)
- time of the action
- Days (days of the week, days of the month) and months on which the action should be carried out
- action (DALI command)

Sequencer

The DALI-2 IoT4 allows the creation of sequences - an automatic playback of DALI command sequences.

A sequence consists of a series of a maximum of 16 DALI commands to, for example, implement a sequence of brightness and colour changes (scenes). Delays can be set between the commands. A sequence can be called once or with repetitions (loop). The effective range to be controlled can be defined across lines.

Circadian function

With the circadian function, the DALI IoT4 offers the possibility of automatically adjusting the colour temperature of DT8-capable tunable white luminaires. Two daily curves (for the longest and shortest day of the year, June and December) can be defined, each with 24 reference points.

The time is used to interpolate between the individual reference points. The same applies to the reference points depending on the date.

The colour temperature of the circadian curve is updated every minute.

The effective range that should be controlled by the circadian curve can be defined across all lines.

Interfaces

Restful API and Websockets

The API documentation and IoT functionalities are explained in more detail in the manual:

[DALI IOT API documentation](#)

Basic services and API documentation are available at (http://<IP_ADDRESS of the DALI-2 IoT>/docs).

Modbus TCP

The device offers a Modbus TCP server, via which DALI commands can be sent and status values can be queried. The Modbus interface does not offer any configuration options for the IoT4 device. The IoT4 does not contain a Modbus client, i.e. no information is output from the IoT4 device on the Modbus interface, so receiving DALI event messages or DALI monitor information via Modbus TCP is not possible.

Modbus TCP/IP is a variant of the serial Modbus communication protocol for TCP/IP networks via port 502. The following Modbus functions are supported:

Function Name	Function Code	Description
Read Multiple Holding Registers	03	Read Data Blocks From Device
Write Multiple Holding Registers	16	Write Data Blocks To Device
Read/Write Holding Registers	23	First Write, then Read from Specific Address, function used to send DALI commands

Using the write and read access to the Modbus registers, the individual DALI lines can be accessed directly (e.g. send DALI commands) or holding registers can be read (e.g. query the status and level of all DALI operating devices on a DALI line).

Details on access via Modbus registers and application examples can be found in the manual:https://www.lunatone.com/wp-content/uploads/2025/03/22176625_DALI-2-IoT4_Modbus_Manual_EN_M0028.pdf

DALI-2 IoT4 Node RED

Art.Nr. 22176625-NR and 22176625-PS-NR

<https://nodered.org/>

Node-RED is a programming tool to connect hardware devices, APIs and online services. Many device interfaces are available in the Node-RED library.

The DALI-2 IoT Node-RED serves as a Node-RED host, which means that no additional device is required for Node-RED automations. After installing the DALI-2 IoT Node-RED, the Node-RED Editor can be accessed in any browser at http://<IP_ADDRESS of the DALI-2 IoT>:1880

(If the Node-RED Editor cannot be reached, please check whether the PC and the DALI-2 IoT Node-RED are in the same network and address range.)

Nodes integrated in the DALI-2 IoT Node-RED (Art. Nr.: 89453886-NR) by default are:

- lunatone/node-red-dali
- node-red-dashboard
- node-red-contrib-modbus

Nodes can only be added by Firmware updates of the DALI-2 IoT. Integration of desired additional or other node such as e.g.:

- email
- string
- moment (datetime formatter)
- specific databases
- external services such as Zigbee, ifttt, homekit, aws, chatbots,...

<https://flows.nodered.org/>

as delivery configuration or as firmware update on request.

Node-RED application examples

Various applications for DALI-2 IoT and DALI 4Net are available, including:

Node RED Dashboard: for control and overview of sensor values.

The dashboard page can be opened via any browser, see example for dashboard in Figure 2, page 12. The dashboard can also be used for control via a smartphone, by selecting "Add to start screen" in the browser menu, the dashboard page can be called up like any other application:

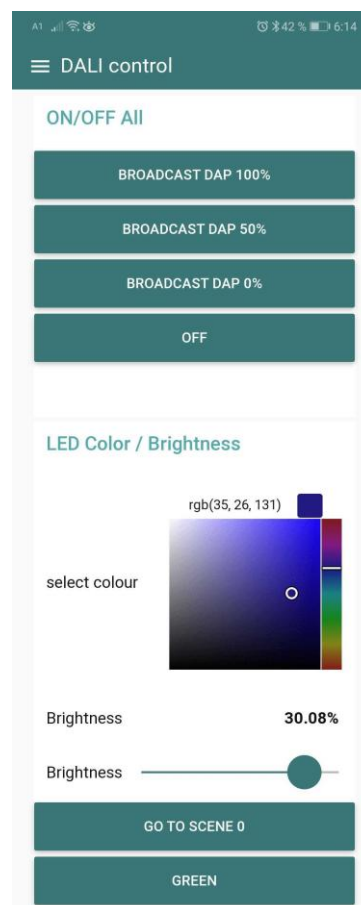
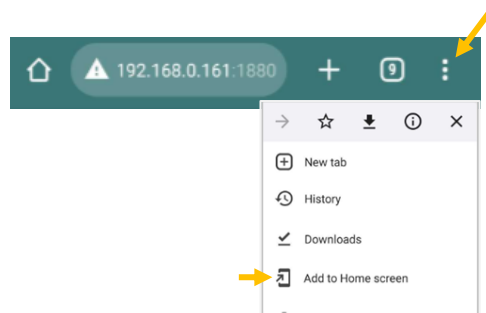

Example 1. - DALI control commands:

The creation of the buttons for sending control commands to the DALI bus is possible with the available Lunatone nodes.

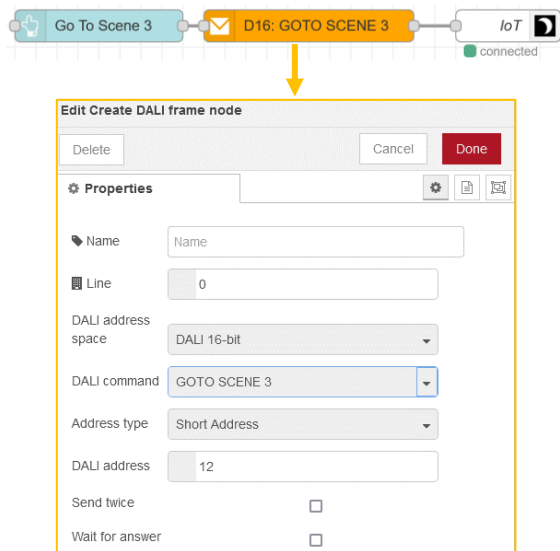

General DALI commands, Queries and more including DALI and DALI-2 are available by drop down – also including DALI-2 event messages.

With the additional function blocks in the application examples also DALI control macros can be easily implemented e.g.

- control of color temperature
- control of color via colour picker

Example 2 - network bridge: forwarding between multiple DALI-2 IoTs for cross-bus control.

Forwarding between multiple DALI-2 IoTs:

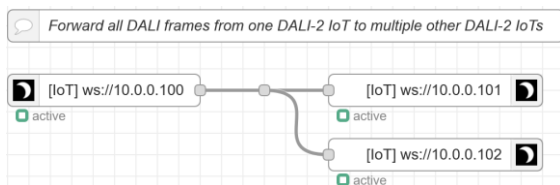

Selective forwarding with filtering:

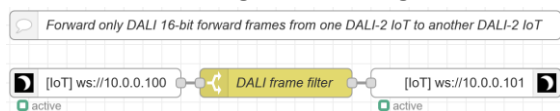

Forwarding from a DALI-2 IoT to a DALI4Net:

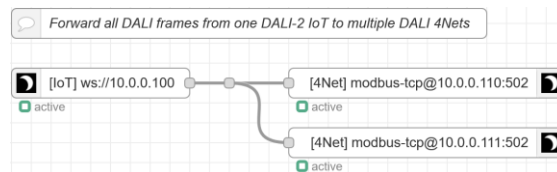

Example 3 - query device status: The light status of DALI devices can be queried and answers can be captured to display the status in the dashboard or add a following action.

Example 4 - sensor values:

Via the web socket connection the DALI-2 Sensor events can be captured and evaluated (DALI-2 event messages of the sensor need to be activated, alternatively the sensor needs to be queried periodically). The sensor values can be extracted from the bus traffic by filtering for the DALI-2 Sensor address and the DALI-2 Event message.

The received sensor values can be used for automations, triggering other actions, or simply to be displayed in the dashboard.

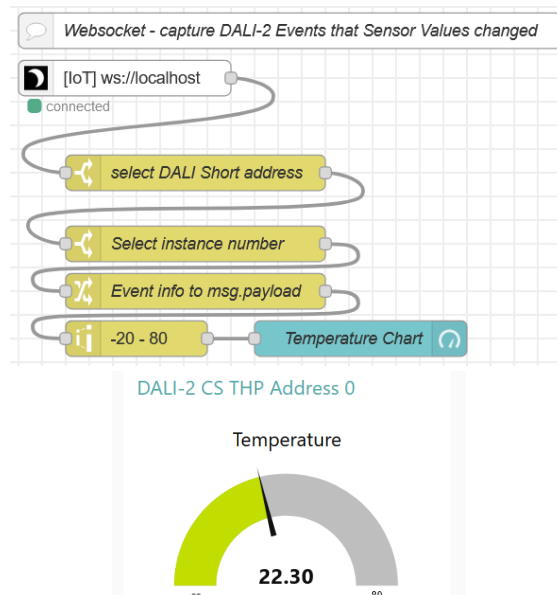

Download Examples:

Different application examples can be downloaded [here](#) as a Node-RED project and opened in the Node-RED Editor.

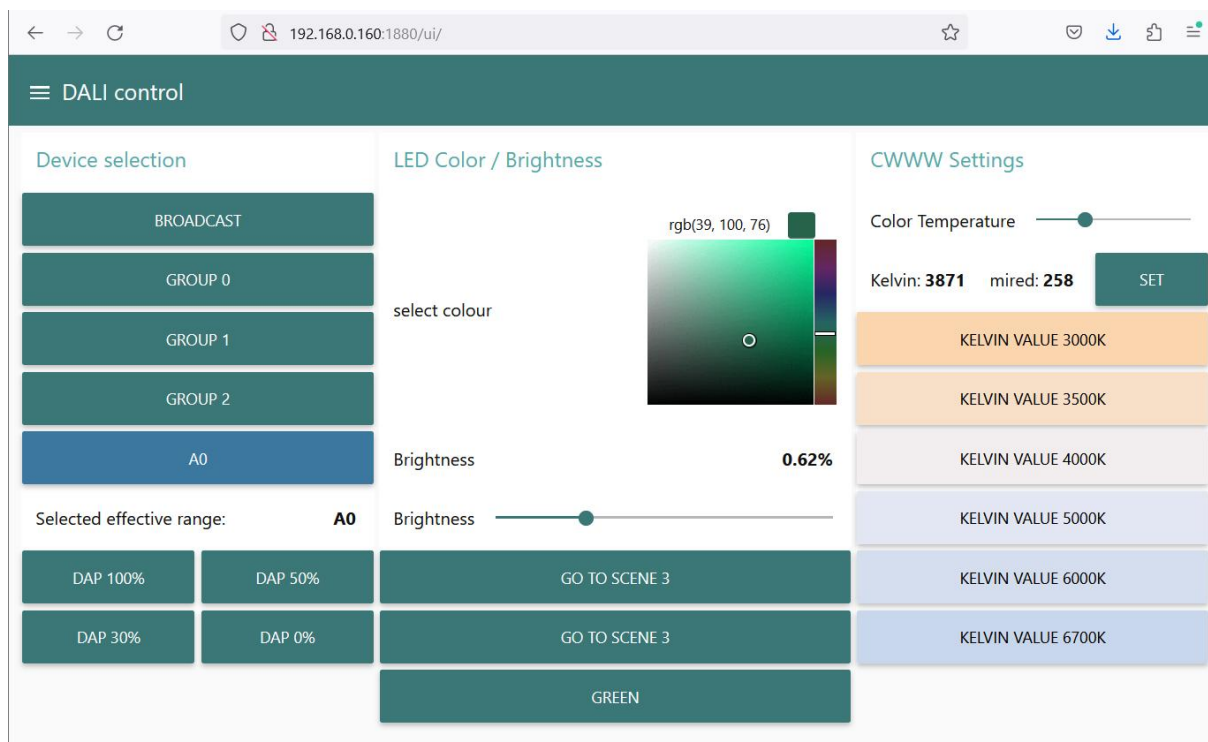

Figure 2 Example for DALI IoT Node RED Dashboard – Tab DALI Control

Web Interface

The DALI IoT web interface allows uploading of macros or loading firmware updates. The web interface can be accessed via a web browser, by entering the IP address of the display in the browser.

Information on the network settings and the IP address of the DALI IoT are in section “Network Connection”, page 7.

The PC, phone or tablet and the display must be in the same network and address range.

Cloud access

The DALI IoT4 interface can be accessed via cloud (tunneling of DALI commands, access to the node-RED host is not supported). Cloud support can be requested via cloudsupport@lunatone.com

Information can be found here: <https://www.lunatone.com/en/product/lunatone-cloud-service/>

Firmware Update

Firmware updates are possible via the web interface of the DALI IoT, see section “Web Interface” on page 12.

On the web interface on the tab “Firmware update” the firmware update file (.ifu) can be uploaded and the update can be started using the "Upload" button, see also Figure 2 below.

The update can take up to 15 minutes. After an automatic restart of the device, the update is complete.

Attention: The device should only be updated not downgraded, a downgrade will lead to data-loss.

Attention: With the browser "Microsoft Edge" problems can occur during updates. It is recommended to use a different browser for firmware updates.

The latest DALI-2 IoT software update file can be found [here](#)

The latest node-red software update file can be found [here](#)

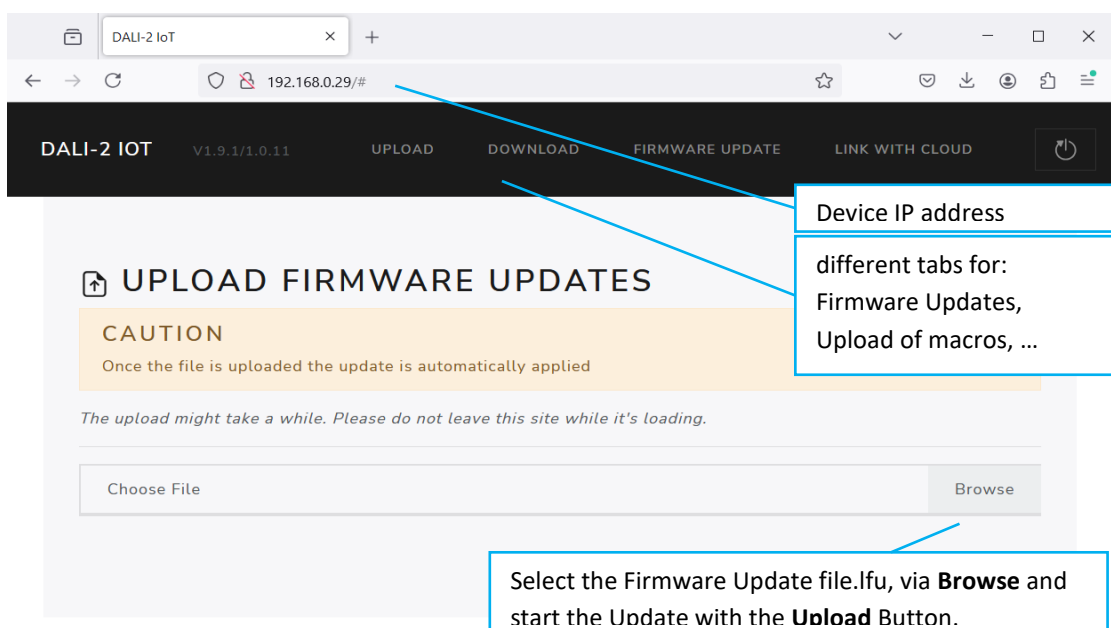

Figure 3 web interface - tab Firmware Update

Frequently Asked Questions

Is the DALI-2 IoT4 Single or Multi Master? the device is a multi master device with collision detection. As a DALI-interface it does not receive a DALI-2 or DALI address.

Disable Ping: The IoT4 sends a ping on the DALI line by default. This can be disabled on the web interface section "General Settings."

Does the device have a battery to store the time settings on a power outage? The IoT4 does not have a battery, if connected to the internet and time settings are set to "automatic datetime" the device will correct the time according to the set timezone

What is the function of the USB port? none, the port is not used

Should one start a bus-scan via the IoT4 in addition to the DALI Cockpit? If the device list in the IoT4 is needed for Restful API calls to single devices an additional addressing scan via the IoT4 should be made. If the functionality remains unused the device list in the DALI IoT should not be loaded to save storage and performance.

Purchase Order Information

Art.Nr. 22176625: DALI-2 IoT4, DALI – LAN interface, 4 DALI lines

Art.Nr. 22176625-PS: DALI-2 IoT4, DALI – LAN interface, 4 DALI lines, integrated DALI power supply per line 120mA

Art.Nr. 22176625: DALI-2 IoT4, DALI – LAN interface & node RED host, 4 DALI lines

Art.Nr. 22176625-PS: DALI-2 IoT4, DALI – LAN interface & node RED host, 4 DALI lines, integrated DALI power supply per line 120mA

Accessories:

Art. Nr.: 24166012-24HS, 24VDC/300mA power supply, DIN rail

Art. Nr.: 24166173-24HS, 24VDC/1000mA power supply, DIN rail

Additional Information and Equipment

DALI-2 IoT API manual

https://www.lunatone.com/wp-content/uploads/2021/08/89453886_DALI2_IOT_API_Dokumentation_EN_M0023.pdf

DALI-2 IoT4 Modbus TCP Manual

https://www.lunatone.com/wp-content/uploads/2025/03/22176625_DALI-2-IoT4_Modbus_Manual_EN_M0028.pdf

DALI-2 IoT Node Red examples

www.lunatone.at/projects/Display_and_IoT/IoT-Node-RED-examples.zip

DALI-Cockpit – DALI system configuration tool, free when using a Lunatone interface device

<https://www.lunatone.com/en/product/dali-cockpit/>

Lunatone DALI products

www.lunatone.com/en/

Lunatone datasheets and manuals

www.lunatone.com/en/downloads-a-z/

Contact

Technical Support: support@lunatone.com

Requests: sales@lunatone.com

www.lunatone.com



Disclaimer

Subject to change. Information provided without guarantee. The datasheet refers to the current delivery.

The compatibility with other devices must be tested in advance to the installation.