

Driver LC 240W 48V DS L

with integrated DALI repeater / isolator



Product description

- _ Safety isolated device with 48V SELV output
- _ Compatible with 48V DC components (e.g. DC MULTI / MICRO)
- _ Max. output power 240 W
- _ Up to 94.7 % efficiency
- _ Nominal lifetime up to 50,000 h
- _ For installations of protection class II and protection class III
- _ Temperature protection as per EN 61347-2-13 C5e
- _ 5 years guarantee (conditions at <https://www.tridonic.com/en/int/services/manufacturer-guarantee-conditions>)

Housing properties

- _ Linear metal housing in the colour black
- _ Type of protection IP20

Interfaces

- _ Terminal blocks: 45° push terminals
- _ Strain relief as an accessory option for independent applications

Functions

- _ Double isolated DALI repeater
- _ Max output power supply on DS 200 mA
- _ Hot plugin of single LED fixtures possible
- _ Overtemperature protection
- _ Short-circuit protection
- _ Overload protection

Website

<http://www.tridonic.com/28005711>



Linear



High bay



Decorative



Downlights



Spotlights



Free-standing



Area



Floor | Wall



Street

Driver LC 240W 48V DS L
with integrated DALI repeater / isolator

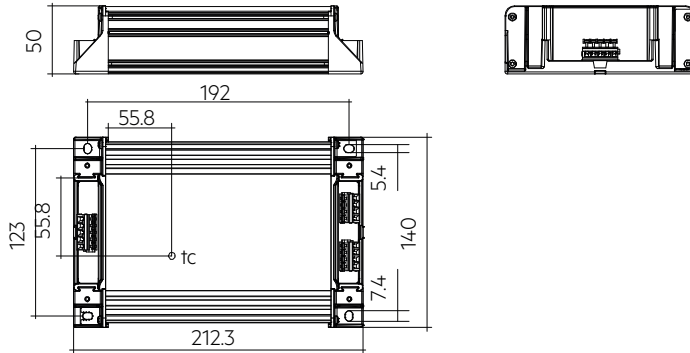

Ordering data

Type	Article number	Packaging, carton	Packaging, pallet	Weight per pc.
LC 240W 48V DS L	28005711	1 pc(s).	96 pc(s).	0.855 kg

Technical data

Rated supply voltage	220 – 240 V
AC voltage range	198 – 264 V
Mains frequency	50 / 60 Hz
Overvoltage protection	320 V AC, 20 h
Typ. rated current (at 230 V, 50 Hz, full load)	1,120 mA
Leakage current (at 230 V, 50 Hz, full load)	< 500 µA
Max. input power	254.5 W
Output power range (P _{rated})	2.4 – 240 W
Typ. efficiency (at 230 V, 50 Hz, full load)	94.7 %
λ over full operating range (max.)	0.99
λ over full operating range (min.)	0.22C
In-rush current (peak / duration)	96 A / 158 µs
THD (at 230 V, 50 Hz, full load)	< 6 %
Output LF current ripple (< 120 Hz)	± 5 %
Max. output voltage (U-OUT)	60 V
Mains surge capability (between L - N)	1 kV
Mains surge capability (between L/N - PE)	2 kV
Surge voltage at output side (against PE)	< 500 V
Lifetime	up to 100,000 h
Guarantee (conditions at www.tridonic.com)	5 Year(s)
Dimensions L x W x H	215 x 140 x 50 mm

Approval marks



Specific technical data

Type	Load	Output voltage	Output current	Max. output power (at full load)	Typ. power consumption (at full load)	Typ. current consumption	t _c point max.	Ambient temperature t _a
LC 240W 48V DS L	1 %	48 V	50 mA	2.4 W	4.7 W	95 mA	70 °C	-20 ... +65 °C
LC 240W 48V DS L	10 %	48 V	500 mA	24.0 W	29.0 W	165 mA	70 °C	-20 ... +65 °C
LC 240W 48V DS L	20 %	48 V	1,000 mA	48.0 W	53.5 W	255 mA	70 °C	-20 ... +65 °C
LC 240W 48V DS L	30 %	48 V	1,500 mA	72.0 W	78.0 W	355 mA	70 °C	-20 ... +65 °C
LC 240W 48V DS L	40 %	48 V	2,000 mA	96.0 W	102.5 W	460 mA	70 °C	-20 ... +65 °C
LC 240W 48V DS L	50 %	48 V	2,500 mA	120.0 W	127.5 W	560 mA	70 °C	-20 ... +60 °C
LC 240W 48V DS L	60 %	48 V	3,000 mA	144.0 W	152.5 W	670 mA	70 °C	-20 ... +60 °C
LC 240W 48V DS L	70 %	48 V	3,500 mA	168.0 W	177.0 W	780 mA	70 °C	-20 ... +60 °C
LC 240W 48V DS L	80 %	48 V	4,000 mA	192.0 W	203.0 W	885 mA	70 °C	-20 ... +60 °C
LC 240W 48V DS L	90 %	48 V	4,500 mA	216.0 W	227.0 W	990 mA	65 °C	-20 ... +50 °C
LC 240W 48V DS L	100 %	48 V	5,000 mA	240.0 W	254.5 W	1,110 mA	65 °C	-20 ... +50 °C

① For independent use cases t_a max. is reduced by 3 °C.

ACU L 85x50mm CLIP-ON SR SET

Accessory

**Product description**

- _ Optional strain-relief for independent applications
- _ Easy and tool-free mounting to the LED driver
- _ Screws can be used if necessary. For US variants, it's mandatory.
- _ Transforms the LED driver into a fully class II compatible LED driver (e.g. ceiling installation)
- _ Use each strain relief channel for one cable only
- _ Overall length = length L (LED driver) + 2 x 50 mm (strain-relief set)
- _ A carton of 1 pcs. is equal to 1 set, each with 1x Input and 1x Output strain-relief part

Website

<http://www.tridonic.com/28005911>

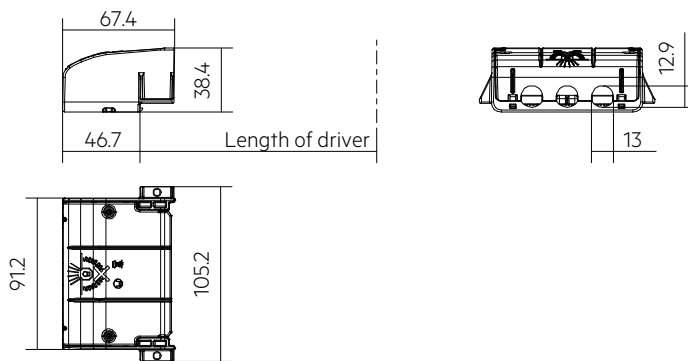
**Ordering data**

Type	Article number	Packaging, outer box	Weight per pc.
ACU L 85x50mm CLIP-ON SR SET	28005911	100 pc(s).	0.14 kg

1. Standards

EN 55015
 EN 61000-3-2
 EN 61000-3-3
 EN 61347-1
 EN 61347-2-13
 EN 62384
 EN 61547
 According to EN 62386-101

2. Thermal details and lifetime

2.1 Expected lifetime

Expected lifetime

Type	Output load	ta	40 °C	45 °C	50 °C	55 °C	60 °C	65 °C	Built-in
				42 °C	47 °C	52 °C	57 °C	62 °C	Independent
LC 240W 48V DS L	0 – 100 W	tc	47 °C	52 °C	57 °C	62 °C	66 °C	70 °C	
		Lifetime	>100,000 h	>100,000 h	>100,000 h	>100,000 h	>100,000 h	74,000 h	
	100 – 200 W	tc	54 °C	57 °C	61 °C	65 °C	70 °C	–	
		Lifetime	>100,000 h	>100,000 h	92,000 h	66,000 h	50,000 h	–	
200 – 240 W	tc	57 °C	62 °C	65 °C	–	–	–		
	Lifetime	78,000 h	59,000 h	50,000 h	–	–	–		

The LED control gear is designed for a lifetime stated above under reference conditions and with a failure probability of less than 10 %.

The relation of tc to ta temperature depends also on the luminaire design.

If the measured tc temperature is approx. 5 K below tc max., ta temperature should be checked and eventually critical components (e.g. ELCAP) measured. Detailed information on request.

3. Installation / wiring

3.1 Circuit diagram

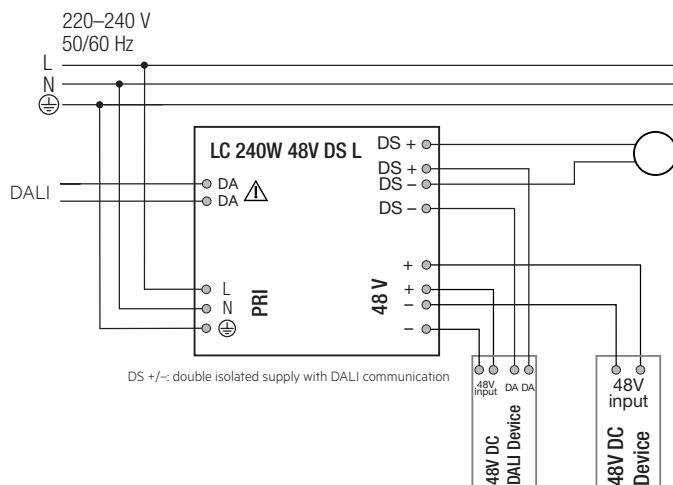

3.2 Terminals

For wiring use stranded wire with ferrules or solid wire from 0.1 – 2.5 mm².
 For perfect function of the push-wire terminals (WAGO 256) the strip length should be 5 – 6 mm.

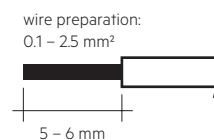

Use one wire for each terminal connector only.
 Use each strain relief channel for one cable only.

3.4 Loose wiring

Terminals

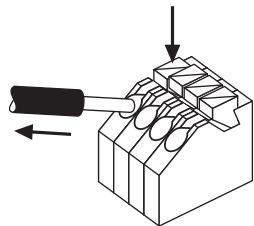

Release of the wiring

Press down the “push button” and remove the cable from front.

3.5 Wiring guidelines

- The 48 V cables should be run separately from the mains connections and mains cables to ensure good EMC conditions.
- The 48 V DC output wiring should be kept as short as possible to ensure good EMC.
- To comply with EMC regulations run the secondary wires (48V output) in parallel.
- No additional measures are required for cable lengths of up to 30 meters.
- The max. secondary cable length is 30 m (60 m circuit) till beginning of a track light.
- The last 48V DC device in the light track must be supplied with at least 46 V.
- To avoid damage of the Driver, the wiring must be protected against short circuits to earth (sharp edged metal parts, metal cable clips, louver, etc.).

3.6 Function of the earth terminal ⊕

The device has to be earthed to fulfill EMI requirements. Driver has protective earth connection and is rated as Class I.

3.7 Control terminals



There is a risk of electric shock when touching these terminals in case of failure.

3.8 Fixing conditions when using as independent Driver with Clip-On

Dry, acidfree, oilfree, fatfree. It is not allowed to exceed the maximum ambient temperature (t_a) stated on the device. Minimum distances stated below are recommendations and depend on the actual luminaire. Device is not suitable for fixing in corner.

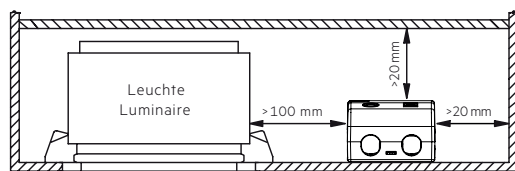

Device not suitable for covering with thermally insulating material according to IEC 60598-1 Ed.9

3.9 Strain Relief Accessories

28005911 - ACU L 85x50mm CLIP-ON SR SET

3.10 Independent control gear classification



“Do not cover”, “non-IC” and “IC” classified control gear are recommended to be installed according to the Fixing conditions in 3.4.

4. Electrical values

4.1 Efficiency vs. load

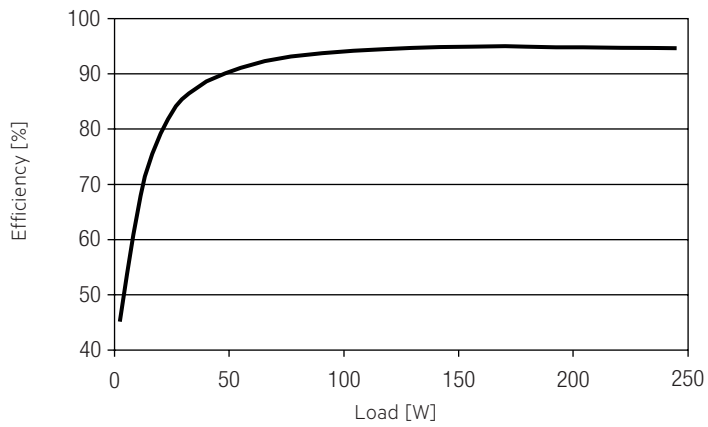

4.2 Power factor vs. Load

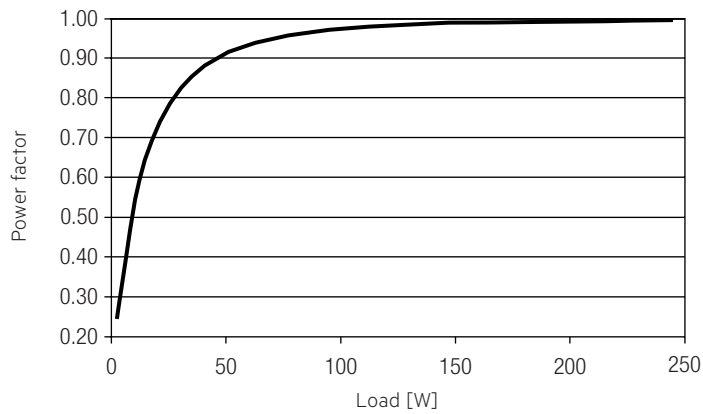

4.3 THD vs. Load

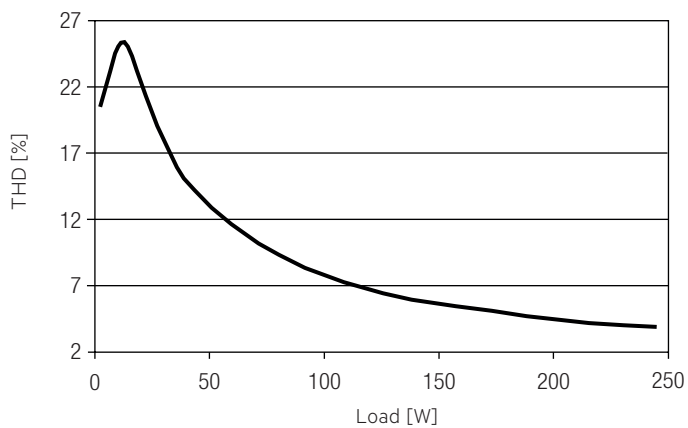

4.4 Maximum loading of automatic circuit breakers in relation to inrush current

Automatic circuit breaker type	C10	C13	C16	C20	B10	B13	B16	B20	Inrush current	
Installation Ø	1.5 mm ²	1.5 mm ²	2.5 mm ²	2.5 mm ²	1.5 mm ²	1.5 mm ²	2.5 mm ²	2.5 mm ²	I_{max}	time
LC 240W 48V DS L	5	7	9	11	3	4	5	6	96 A	158 µs

These are max. values calculated out of inrush current! Please consider not to exceed the maximum rated continuous current of the circuit breaker.

Calculation uses typical values from ABB series S200 as a reference.

Actual values may differ due to used circuit breaker types and installation environment.

4.5 Harmonic distortion in the mains supply (at 230 V / 50 Hz and full load) in %

	THD	3.	5.	7.	9.	11.
LC 240W 48V DS L	6	3	5	1.3	1.5	1

5. Interfaces / communication

5.1 Control input DALI

Digital DALI signal can be wired on the terminals DA.

The control signal on primary side is not SELV. Control cable has to be installed in accordance to the requirements of low voltage installations.

Different functions depending on each module.

6. Functions

6.1 Short-circuit behaviour

In case of a short-circuit at the output the output is switched off. After restart of the DC power supply the output will be activated again. The restart can be done via mains reset.

6.2 Overload protection

If the output power range is exceeded by a defined internal limit, the DC power supply will give a signal to the DC/DC-LED driver, it will blink 20 times with a 2 second interval.

- After 20 attempts, the device switches off and must be restarted via Mains reset

6.3 Overtemperature protection

The DC power supply will blink 3 times, after 30 s break, it checks again, if:

- there is no overtemperature, then the device will go in normal operation.
- there is still overtemperature, then the device will blink again 3 times.

6.4 With integrated DALI repeater / isolator

The function fulfils the current requirements (not yet finally specified by Integrated DALI power supply (DS) according to EN 62386-101.

6.5 No-Load operation

Operation without load (no-load) is not allowed. Driver will not shut down or not get damaged in case of no-load operation.

7. Miscellaneous

7.1 Insulation and electric strength testing of luminaires

Electronic devices can be damaged by high voltage. This has to be considered during the routine testing of the luminaires in production.

According to IEC 60598-1 Annex Q (informative only!) or ENEC 303-Annex A, each luminaire should be submitted to an insulation test with 500 V_{DC} for 1 second. This test voltage should be connected between the interconnected phase and neutral terminals and the earth terminal.

The insulation resistance must be at least 2 MΩ.

As an alternative, IEC 60598-1 Annex Q describes a test of the electrical strength with 1500 V_{AC} (or 1.414 x 1500 V_{DC}). To avoid damage to the electronic devices this test must not be conducted.

7.2 Conditions of use and storage

Humidity: 5 % up to max. 85 %,
not condensed
(max. 56 days/year at 85 %)

Storage temperature: -40 °C up to max. +80 °C

The devices have to be acclimatised to the specified temperature range (ta) before they can be operated.

The LED driver is declared as inbuilt LED controlgear, meaning it is intended to be used within a luminaire enclosure.

If the product is used outside a luminaire, the installation must provide suitable protection for people and environment (e.g. in illuminated ceilings).

7.3 Additional information

Additional technical information at www.tridonic.com → Technical Data

Lifetime declarations are informative and represent no warranty claim. No warranty if device was opened.